

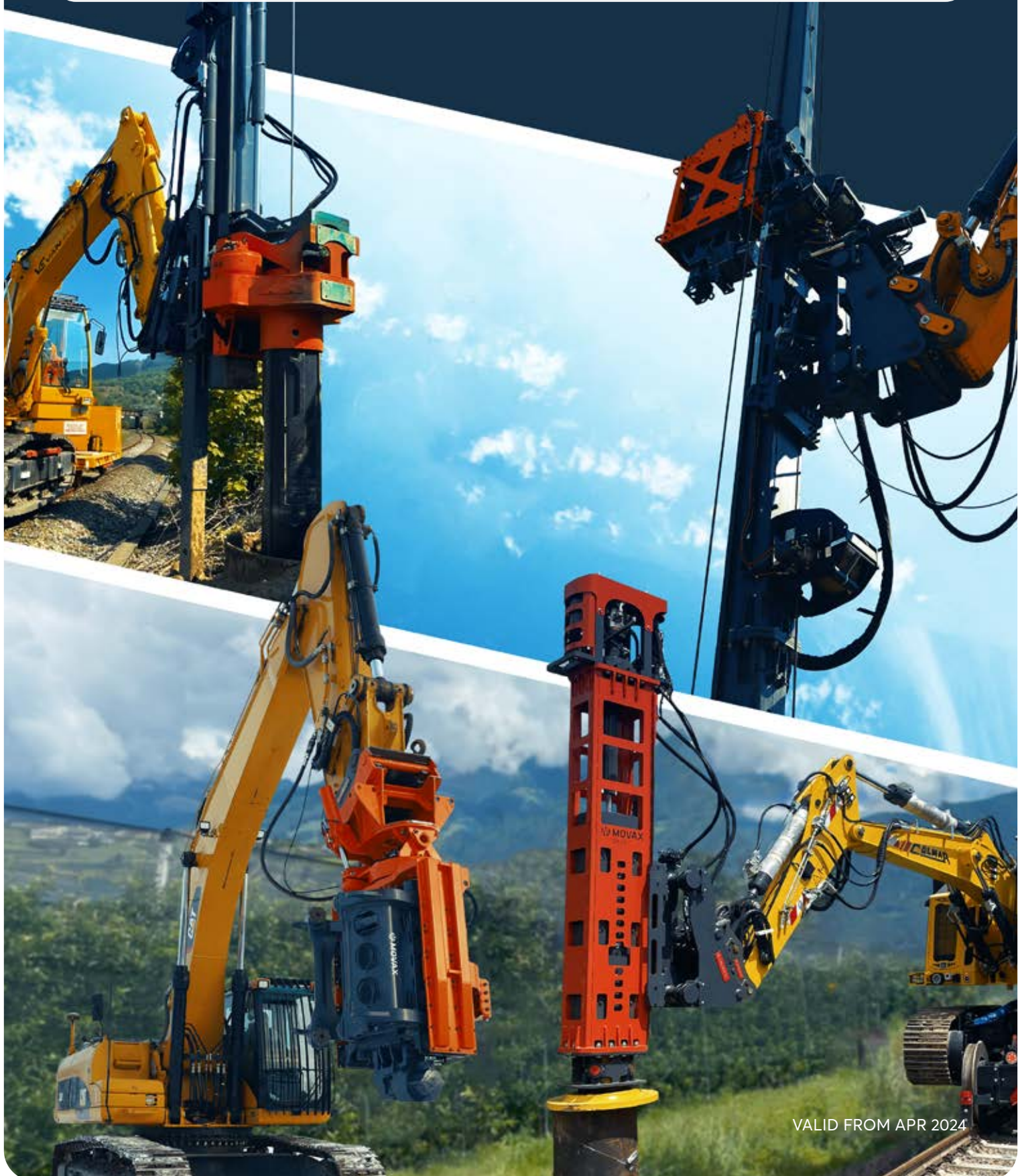

Total Piling Solutions

PRODUCT
CATALOGUE
2024



VALID FROM APR 2024



total solution for PILING & FOUNDATION



CIVIL



ROAD



RAIL



UTILITIES



ENERGY &
ENVIRONMENT



PIERS &
WATERWAYS

TABLE OF CONTENTS

MOVAX WAY-OF-PILING		PILING DRILLS		MOVAX CONTROL SYSTEM	
Introduction	4	Introduction	58	Introduction	105
Piling and foundation equipment	6	Features	61	Features	107
Customised solutions	8	Technical data		mControl+ PRO	
SOLUTIONS	10	Models KB-70L & 70S	62	Introduction	108
SIDE GRIP VIBRATORY PILE DRIVERS		Models TAD-32 & 51	64	Features	109
Introduction	12	MANIPULATORS		Automatic control	110
Technology	14	Introduction	67	Information	112
Features	17	Features	69	mControl+ LITE	
Selection	18	MOVAX modular system	70	Introduction	114
Models SG-80VA/F	20	Technical data	71	Features	115
MOVAX modular system	20	MULTI-TOOL PILING LEADERS		INFORMATION MANAGEMENT	
Modular arms	22	Introduction	72	Introduction	116
Tube arms	23	Features	75	mFleetManagement	118
Bottom clamp	24	MOVAX modular system	76	mLogbook	123
Technical data	26	Selection	78	Project reports	124
Models SG-45(V) to SG-60(V)	28	Technical data		Pile reports	128
MOVAX modular system	28	MPL-300 & 400	80	ADAPTERS 132	
Sheet pile arms	30	Piling hammers	82	QUALITY 135	
Tube arms	31	Vibratory pile drivers	84	SERVICES	
Modular arms	32	Pre-auger rotary drive	86	mFleetCare	137
Bottom clamp	34	CFA rotary drive	88	Globally local support	139
Technical data	36	Rotary drives for DTH	90	BENEFITS 140	
Models SG-15N to 40N	38	Examples			
MOVAX modular system	38	MPL-300 for pre-augering	92		
Modular arms	40	MPL-300 for CFA	93		
Bottom clamp	42	MPL-300 for vibro driving	94		
Technical data	44	MPL-300 for impact driving	95		
PILING HAMMERS		COLUMN STABILISATION LEADERS			
Introduction	47	Introduction	97		
Features	49	Features	98		
Mounting options	50	Technical data	100		
Pile handler	52	Monitoring & reporting	102		
Selection	54				
Pile caps	55				
Technical data	56				



HIGHER PRODUCTIVITY – SIGNIFICANT SAVINGS

INTRODUCTION

Movax Oy, established in 1993, is a Finnish-based, privately-owned world-leading innovator, developer and manufacturer of excavator-mounted piling and foundation equipment with highly advanced automatic control systems and information management solutions.

Movax Oy is the inventor of the modular, vibratory side grip pile driver technology. Movax Oy's inventions have resulted in numerous patents (50+) and its trademark, MOVAX®, is registered and well known for the quality it represents all over the world.

Movax Oy is strongly committed to continuously develop its products and services in close cooperation with its customers and local partners.



1993

Established in Hämeenlinna, Finland

1996-1997

1st auto-steering for hydraulic excavator

2009

ISO 9001 certificate

2012

Resonance-free side grip pile driver

2015

1st DH piling hammers
1000th delivery



1994

1st side grip pile driver

2006

Terra Patris Group main owner

New factory in Hämeenlinna

2011

New generation modular side grip (SG) pile driver

2014

Introduction of new generation MCS Lite & Pro Control Systems

MAJOR MILESTONES

A TOTAL SOLUTION.

Movax Oy focuses solely on solutions for the piling & foundation industry. The comprehensive range of excavator-mounted piling & foundation equipment and customized solutions cover a complete range of piling technologies - including both driven and bored piles.

UNIQUE, VALUE-ADDING TECHNOLOGY.

Movax Oy's piling and foundation equipment provide the optimum way-of-working - MOVAX WAY-OF-PILING™ - when constructing foundations, building retaining walls, both temporary and permanent, cofferdams and when performing trenching and excavation work and soil stabilisation in a wide range of applications.

GLOBALLY LOCAL CUSTOMER CARE.

Movax Oy focuses on superior customer service and support together with a world-wide network of local partners, established in more than 30 countries all over the world.

GLOBALLY PROVEN.

With more than 30 years of experience and more than 3000 units delivered to all over the world, MOVAX has a deep understanding and know-how of varying site and soil conditions - and of all kinds of different type of excavators and rail roaders.

Movax Oy's experience also covers a wide range of applications ranging from Rail, Road and Civil to Waterways & Piers, Utilities and Environmental & Energy.

QUALITY BUILT-TO-LAST.

MOVAX is made with high-class materials, equipment and components - and modern, state-of-the-art production technologies ensuring the highest possible quality - and availability.

Movax Oy's Quality Management Systems is certified in accordance with ISO 9001; and MOVAX Oy's products with the CE and UKCA marking.

MOVAX way-of-piling™

Higher productivity – Significant savings
fast. efficient. versatile. safe. accurate. reliable.

2017

1st MPM manipulator



2020

1st MPL
Multi-tool piling
leader with CFA
rotary drive



2022

Introduction of next generation mControl+™
Control System with autoT™ (tip control)

1st MPL-multi tool piling leader with DTH



3000



2019

MCS for electronically controlled
excavators

MOVAX Information Management
System with mLogbook™ and
mFleetManagement™

1st KB kelly-bar piling drill

1st MPL multi-tool piling leader with
pre-auger rotary drive

2021

1st MPL-multi-tool piling leader
with TG vibratory pile driver

MCS with CAN bus control

KB kelly bar piling drill
with 20 m drilling depth

2023

Introduction of nextGeneration
side grip pile driver with
variable active moment

Introduction of MOVAX SOLAR
side grip pile driver for H-, sigma-
and c-profiles

INTRODUCTION

PILING & FOUNDATION EQUIPMENT

MOVAX excavator mounted piling equipment are available for different piling technologies, including driven and bored piles, for varying conditions and requirements and for all kinds of piles including sheet piles, H-beams, tubular steel piles, timber piles - and for cast-in-situ, concrete piling.



SIDE GRIP PILE DRIVERS

SIDE GRIP PILE DRIVERS (SG) are the optimum solution for a wide range of piling requirements and a variety of site and soil conditions – especially when a high-degree of precision is required, and for piling in sensitive environments and when limited space or access is available.

The same unit can handle, pitch and drive piles and is capable of accomplishing the whole process without the need of manual handling or assisting machinery.

PILING HAMMERS

Piling hammers (DH) are utilised to drive load-bearing piles and to assist in sheet pile driving, even in the most difficult soil conditions.

MOVAX piling hammers are the optimum solution to complete a pile installation after reaching refusal with a side grip pile driver or when load testing is required.

The piling hammers can be mounted directly onto the excavator, onto MOVAX Multi-tool piling leader, or a third-party piling rig or crane.

PILING DRILLS

Piling drills (TAD/KB) are designed for cast in-situ and other earth-removal tasks; and the KB-model also for cased drilling.

MOVAX piling drills are especially suitable for sites with confined spaces and when limited space or headroom is available.



MANIPULATORS

Manipulators (MPM) are designed for fast, flexible and efficient handling of different kinds of masts, gantries, and poles as well as a wide range of piles. Soft gripping surfaces are available to prevent damage of sensitive surfaces or coatings.

The MOVAX manipulator is designed for superior maneuverability, safety, precision and accuracy.

CONTROL



The **MOVAX Control System (mControl+)** links the excavator with MOVAX's piling equipment. The system controls the auxiliary hydraulics of the excavator and all the functions of MOVAX's piling equipment.

The control system is a vital - *and integral* - part of the MOVAX way-of-piling ensuring the highest possible production rates and quality of installation.

INFORMATION



MOVAX Information Management System (MIMS) provides essential information about the piling process/pile installation and about the MOVAX piling equipment itself.

mLogbook provides a tool to efficiently monitor and report the piling works saving both time and cost - whereas **mFleetManagement** ensures the maximum availability of the MOVAX piling equipment.

INTRODUCTION

CUSTOMISED SOLUTIONS

MOVAX customised solutions include Multi-tool piling leaders for a wide range of piling and foundation requirements and Column stabilisation leaders for soil improvement.

Excavator mounted MOVAX Multi-tool piling leaders are available with a wide range of tooling for driven, bored and drilled piles - and for varying site and soil conditions. Excavator mounted MOVAX Column stabilisation leaders are suitable for dry binder material.



MULTI-TOOL PILING LEADERS

MOVAX Multi-tool piling leaders are a multi-purpose piling leaders designed for medium to large size excavators. Tooling alternatives include vibratory pile drivers, hydraulic impact type hammers, hydraulic hammers (rock breakers) and rotary drives for pre-augering, CFA (continuous flight auger) and DTH (down-the-hole) piling.

CONTROL



The **MOVAX Control System (mControl+)** links the excavator with MOVAX's customised solutions. The system controls the auxiliary hydraulics of the excavator and all the functions of MOVAX's multi-tool piling leader and its tooling; and the column stabilisation leader.

The control system is a vital - *and integral* - part of the MOVAX way-of-piling ensuring the highest possible production rates and quality of installation.

INFORMATION MANAGEMENT

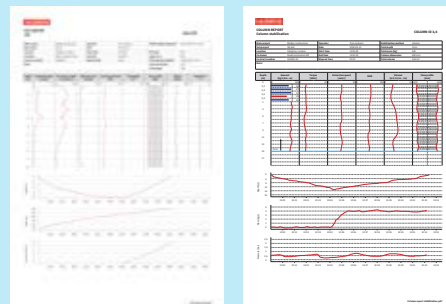

MOVAX Information Management System (MIMS) provides essential information about the piling process/pile installation and about the multi-tool piling leader and its tooling; and the column stabilisation leader.

mLogbook provides a tool to efficiently monitor and report the piling works saving both time and cost - whereas **mFleetManagement** ensures the maximum availability of the MOVAX piling equipment.



SOIL IMPROVEMENT LEADERS

MOVAX Column Stabilisation Leaders are designed for dry binder material and operated with medium to large size excavators as the carrier.

SOLUTIONS



RAIL



ROAD



UTILITIES



ENERGY &



CIVIL



ENVIRONMENT



PIERS & WATERWAYS

INTRODUCTION

SIDE GRIP TECHNOLOGY

MOVAX Side grip pile drivers are excavator-mounted, high-frequency, vibratory-type pile drivers providing the optimum solution for a wide range of piling requirements – especially when a high degree of precision is required; and for piling in sensitive environments and when limited space, head room or access is available.



HANDLING

HIGHER PRODUCTIVITY – SIGNIFICANT SAVINGS

Efficient. Fast. Versatile. Accurate. Safe. Reliable.

The same unit can handle, pitch and drive – and extract – different type of piles and is capable of accomplishing the entire piling process without the need of manual handling or assisting machinery. Furthermore there is no need for additional work, material and tools.



PITCHING

DRIVING/EXTRACTING



SIDE GRIP VIBRATORY PILE DRIVERS TECHNOLOGY

Vibratory pile drivers work by reducing the resistance and formation of the ground by the means of vibration. Vertical vibrations are transferred from the vibratory pile driver to the pile via a hydraulic arm or clamp (gripping the pile). The vibration then travels from the pile to the soil, thus reducing the friction between the pile and the ground allowing the pile to be driven or extracted with less force. The pile is driven to the ground by a combination of the vibrator's weight, centrifugal force it produces and the downward force put out by the excavator.

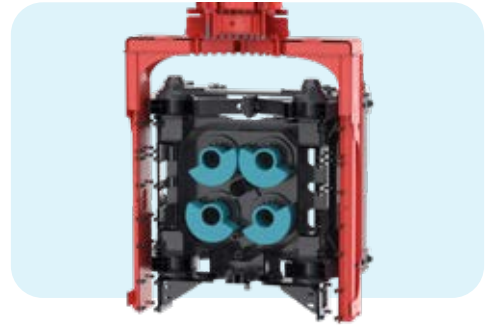

The nature of vibration is to move through matter - everything has its natural resonance, i.e. the frequency in which they have a tendency to vibrate and oscillate. In order to avoid oscillation and thus disturbances to the surroundings, including the ground itself, buildings and structures, it is recommendable to avoid vibrating at natural frequencies.

MOVAX side grip vibratory pile drivers operate at high frequencies (above 38 Hz/2300 rpm) in order to avoid oscillation at the natural frequencies of the surrounding structures - and are available with variable active (VA) moment, resonance-free (V) and with fixed eccentric moment (F/STD/N).



Variable active
(VA)

Resonance-free
(V)

Fixed
(F)

Standard
(STD)

Lite
(N)

1993

Established in
Hämeenlinna, Finland

1995-2000

SP-40, SP-50:
B, C and D-models

2006-2012

SP-50, SP-60:
F-models



1994

1st side grip pile driver,
UV-50/UV-75

2000-2007

SP-40, SP-50, SP-60:
E-models



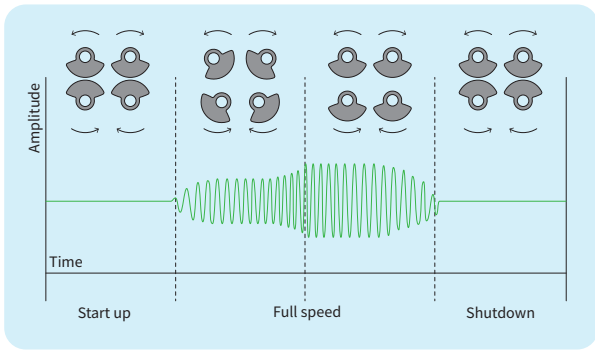

Variable active eccentric moment VA-models

The variable active technology allow the adjustment of the eccentric moment - and thus the amplitude - during pile driving or extraction. The variable active moment optimizes the use of the excavators hydraulic power by maintaining the highest possible force in challenging soil conditions and preventing the formation of resonance frequencies throughout the piling process.

The start-up and shutdown of the **MOVAX variable active (VA)** models is always resonance free – both when using the ‘active mode’ or the ‘fixed mode’ – thus minimizing any disturbances to the surrounding soil or structures.

Resonance-free V-models

The resonance-free technology allow for starting up and shutting down the side grip pile driver without vibration. This is achieved by shifting the upper row eccentrics in respect to the lower row eccentrics. The total eccentric moment of the **MOVAX resonance free (V)-models** can be switched from 0% during start-up to 100% during operation and back to 0% during shut down thus minimizing any disturbances to the surrounding soil or structures.

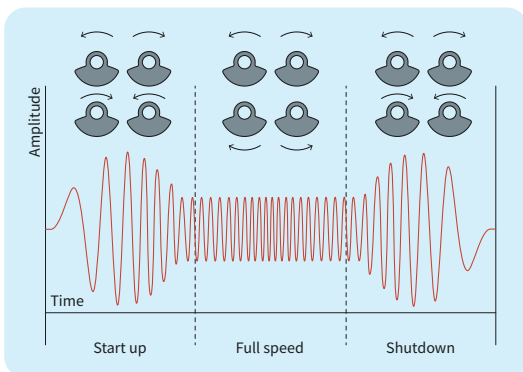
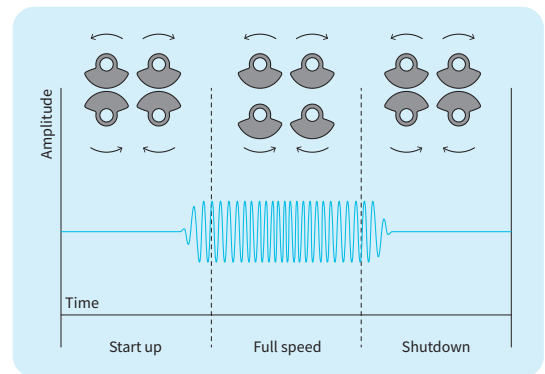

Fixed eccentric moment F, STD & LITE -models

MOVAX fixed eccentric (F, STD & LITE)-models are high frequency (2300-3000 rpm/38- 50 Hz) vibratory pile drivers. The fixed eccentric moment pile drivers are suitable for a wide range of piling works in different site and soil conditions when there is no need to minimize disturbances to the surroundings.

2011-2013

new Generation modular side grip (SG) pile driver

2023

next Generation Variable active (SG-VA) side grip pile driver: models SG-80VA/F

2012-2015

Resonance-free modular (SG-V) side grip pile driver

2016-2017

SG facelift

2018-2020

SG-LITE series

MOVAX
Total Piling Solutions

2024

Available autumn 2024
Variable active side grip pile drivers
SG-50VA & SG-65VA



SIDE GRIP VIBRATORY PILE DRIVERS

FEATURES

EXCAVATOR-MOUNTED

- Suitable for 7-50 ton excavators.
- Utilizing the hydraulic power and lifting capacity of the excavator or rail roader (carrier).
- Designed to work on any and all wheeled and crawler-type excavators and rail roaders by utilising and commanding the standard auxiliary hydraulics and/or by connecting to the electronic control of the excavator.

COMPREHENSIVE MODEL & SIZE RANGE

- Available in different models, sizes and configurations for different piling requirements and different type of piles ranging sheet piles, trench sheets and, H-beams to tubular steel piles and timber piles
- Available for excavators ranging from 7 to 50 ton – thus always ensuring the optimum size and correct combination of vibratory pile driver and excavator.

HIGH FREQUENCY

- High frequency HF (2300-3000 rpm / 38-50 Hz) vibratory pile driver
- Specifically designed to be used with an excavator or rail roader as carrier

STATE-OF-THE ART VIBRATION TECHNOLOGY

- Variable eccentric moment (VA-models) for optimum performance under all site and soil conditions. VA models are also resonance-free under all operating conditions.
- Available also with resonance-free start/stop only (V) and with fixed eccentric moment (F/STD/LITE).

MOVAX MODULAR SYSTEM

- Versatility based on the MOVAX Modular System™ which enables the use of the same unit for a wide range of different piling requirements, piling work and type of piles.
- Optional handling clamps available for U- & Z-piles (VA/F models, only)

MOVAX CONTROL SYSTEM

- Controlled with the MOVAX Control System, mControl+ LITE or PRO
- mControl+ PRO including automatic tip-control feature for maximised productivity and quality.
- Advanced, real-time monitoring of (VA/F models, only);
 - Clamping pressure (electronically monitored, actual pressure of all individual cylinders)
 - Gear oil pressure
 - Gear oil temperature

MOVAX INFORMATION MANAGEMENT SYSTEM

- mFleetManagement for monitoring MOVAX piling equipment operation, performance and condition.
- Optional mLogbook for monitoring and reporting the piling works.



HANDLING, PITCHING, DRIVING AND EXTRACTING PILES



SIDE GRIP VIBRATORY PILE DRIVERS

SELECTION

The optimal MOVAX side grip pile driver for a specific piling & foundation application is selected based on the following:

- technology (variable active, resonance-free, fixed eccentric)
- excavator brand and model
- soil & site conditions
- pile dimensions (weight & length/diameter)



The configuration i.e. the arms, clamps and/or pads of the MOVAX side grip pile driver are then selected based on the type of piles to be driven.

Model (technology)

MOVAX side grip vibratory pile driver-models are available based on three different (vibro)technologies: variable eccentric moment (VA) with resonance-free start/stop (V) and with fixed eccentric moment (F/STD/LITE).

All MOVAX side grip pile drivers are high frequency-type vibratory pile drivers.

Variable Active (VA) models are selected for the most demanding applications and for sensitive areas where disturbances to the surroundings are to be minimized.

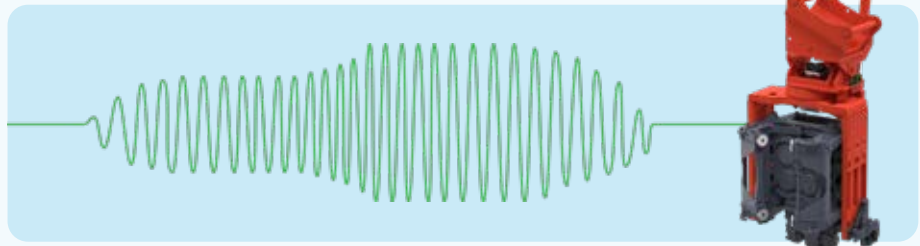

Resonance-free (V) models are selected for sensitive areas where disturbances to the surroundings are to be minimized.

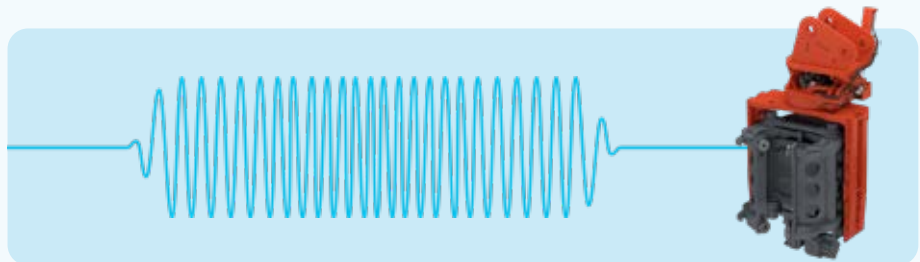

Fixed eccentric (LITE, STD & F) models are selected for a wide range of piling jobs.

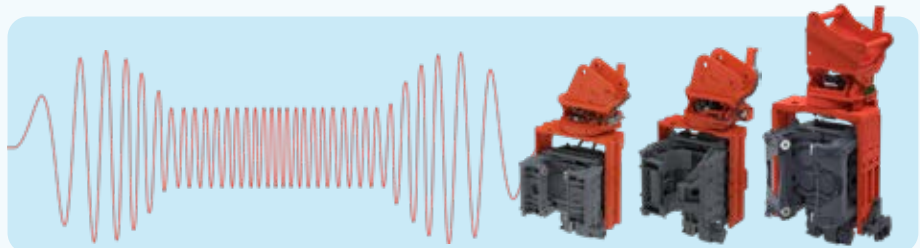

Excavator (brand & model)

The excavator must be suitable – and match – the specific vibratory pile driver in question in regards to hydraulic power (oil flow @ pressure). Thus the excavator brand & model is needed for the correct selection of model.

Type & dimension of piles

In order to select the correct MOVAX model, the type of piles (sheet pile, H-beam, tubular steel pile and/or timber pile) and their dimensions (length, width/depth, OD) are needed.

The arms, clamps and pads are selected based on the piles to be driven. Due to the modular design (*MOVAX Modular System*) the same MOVAX side grip pile driver can be used to drive different type of piles.

Soil conditions

Vibratory pile drivers are suitable for a wide range of soil conditions & N-values (SPT). In order to make a detailed analysis of the suitability of a MOVAX model for a specific project a soil report is needed.

Site conditions

MOVAX side grip pile drivers are the optimum solution for sites with limited access, space or headroom. Standard (STD) and Lite models are selected for a wide range of piling jobs. Variable active (VA) and Resonance-free (V) models are selected for sensitive areas where disturbances to the surroundings are to be minimized.

SELECTION CHART

EXCAVATOR CLASS/ PILE SIZE (length/weight)	33-50 t	28-32 t	23-28 t	20-24 t	17-21 t	13-16 t	7-11 t
6 m x 2800 kg 12 m x 1900 kg 16 m x 1300 kg	SG-80VA SG-80F						
8 m x 2300 kg 12 m x 1800 kg 16 m x 1200 kg		SG-60 SG-60V	SG-50 SG-50V	SG-45 SG-45V			
6 m x 1200 kg 12 m x 1000 kg 16 m x 900 kg					SG-40N	SG-30N	
4 m x 400 kg 6 m x 200 kg							SG-15N
SUITABLE PILES							
Sheet piles / trench sheets		width 400-1200 mm			width 400-1200 mm		width 400-600 mm
H-beams		H100-H500			H100-H400		H100-H140
Timber piles		Ø160-600 mm			Ø120-325 mm		Ø100-200 mm
Tube piles		Ø88.9-1220 mm			Ø88.9-508 mm		Ø88.9- 323.9 mm

The Selection Chart provides the preliminary selection; When making the final selection the excavator engine size and hydraulic system design (oil pump arrangement, oil flow rate/pressure etc.), excavator lifting capacity and stability and soil and site conditions shall be taken into account.

SIDE GRIP VIBRATORY PILE DRIVERS

MOVAX MODULAR SYSTEM

Models SG-80VA/F

The MOVAX Modular System (MMS™) enables the use of the same MOVAX side grip pile driver for a wide range of different type of piles ranging from sheet piles, H-beams and tubular steel piles to timber piles. The MOVAX Modular System includes interchangeable arms, clamps and pads that can easily and efficiently be changed for the different pile types in question.

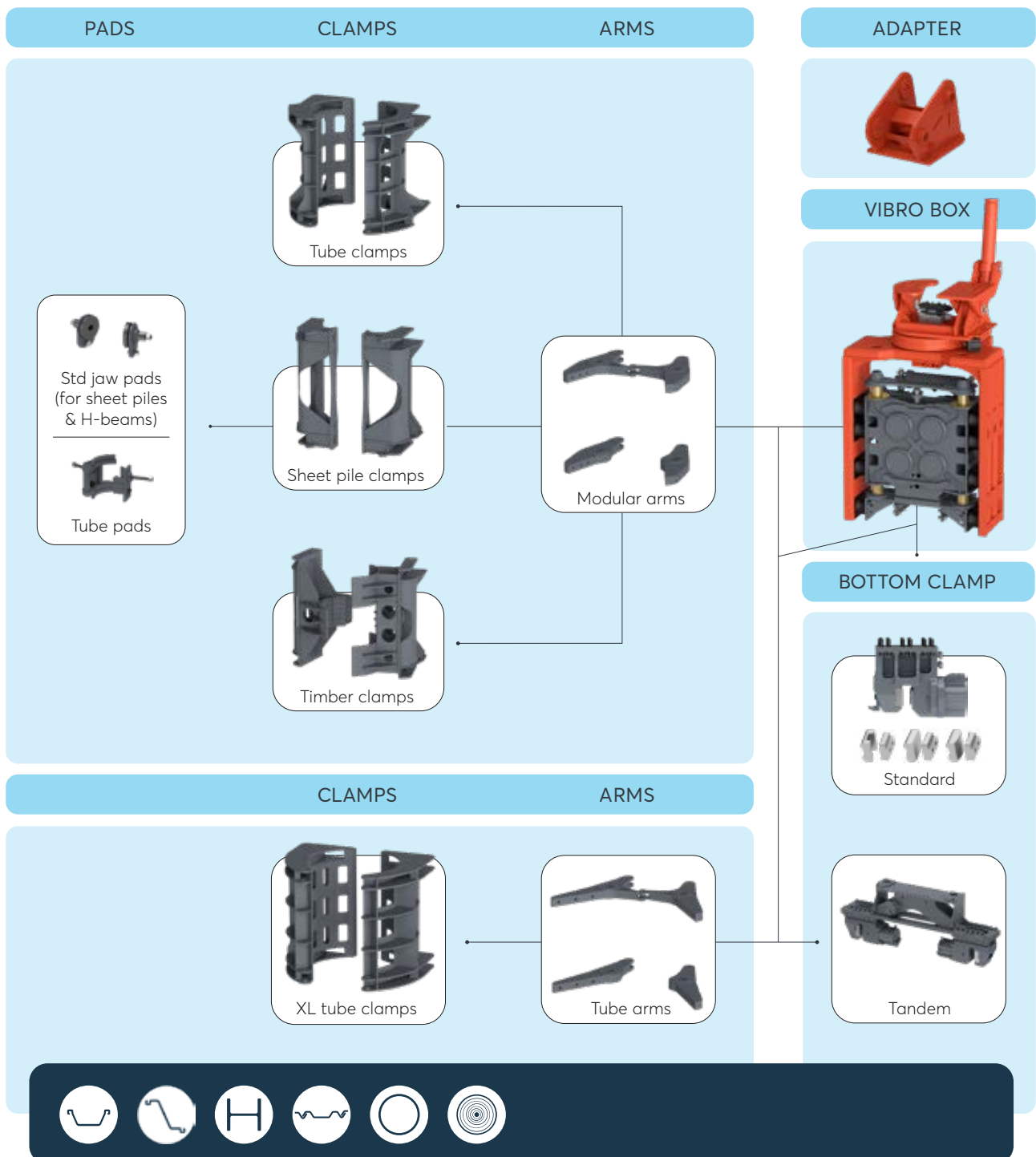

SIDE GRIP VIBRATORY PILE DRIVERS

MOVAX MODULAR SYSTEM

Models SG-80VA/F

MODULAR ARMS

SHEET PILE CLAMPS

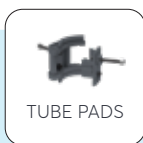

TUBE CLAMPS



TIMBER CLAMPS



TUBE ARMS

XL TUBE CLAMPS



SIDE GRIP VIBRATORY PILE DRIVERS

MODULAR ARMS

Models SG-80VA/F

Modular arms are suitable for driving sheet piles, H-beams, tubular steel piles and timber piles.

Sheet pile clamps are utilised to drive sheet piles and H-beams. The sheet pile clamps can be equipped with tube pads for tubular steel piles up to OD 273 mm. Each tube size requires its own tube pads in order to ensure proper operation.

Tube clamps are utilised for tubular steel piles up to OD 762 mm. Each tube size requires its own tube clamps of matching size.

Timber clamps are utilised to drive timber or wooden piles. A range of round timber piles can be driven with the same timber clamps whereas square timber piles requires clamps of the same size.



TUBE CLAMPS

for tubular steel piles from
OD 88.9 mm up to OD 762 mm:

Standard sizes

Ø 88.9	Ø 168.3	Ø 457
Ø 101.6	Ø 219.1	Ø 508
Ø 114.3	Ø 273	Ø 610
Ø 127	Ø 323.9	Ø 711
Ø 139.7	Ø 406.4	Ø 762



SHEET PILE CLAMPS

Sheet pile/H-beam
w 400–1200 mm/H180-H500

Tube piles up to OD 273

Standard sizes

Ø 88.9	Ø 114.3	Ø 139.7	Ø 219.1
Ø 101.6	Ø 127	Ø 168.3	Ø 273



TIMBER CLAMPS

for timber piles from
OD 160 mm up to 600 mm

A range of timber pile sizes can be
driven with the same timber clamps.

Standard sizes

M Ø 160-420 mm
L Ø 430-600 mm

Customised sizes and special types, for instance for rail tracks, are available by request.

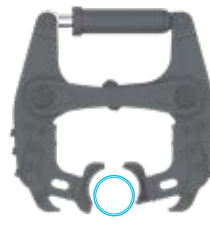
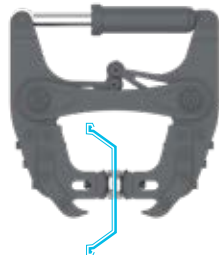

SIDE GRIP VIBRATORY PILE DRIVERS

TUBE ARMS

Models SG-80VA/F

Special modular tube arms are utilised to handle and drive large diameter tubes from 508 mm up to OD 1220 mm. Each tube size requires its own tube clamp of the same size as the tube in order to ensure proper operation.

A tandem bottom clamp is available for the same tube sizes as the tube arms for optimised pile driving of large tubes. The same tandem bottom clamp can be used for the range of the different size tubular steel piles.



XL TUBE CLAMPS
from OD 508 to 1220mm

Standard sizes

Ø 508	Ø 711	Ø 813	Ø 1016
Ø 610	Ø 762	Ø 914	Ø 1220

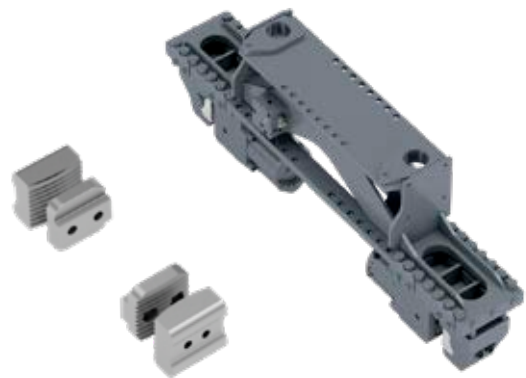

TANDEM BOTTOM CLAMP

Tube pads for tandem bottom clamp
from OD 508 mm up to OD 1220 mm.

TUBE ARMS are designed for the optimum handling, pitching and driving/
extraction of large OD tubes.

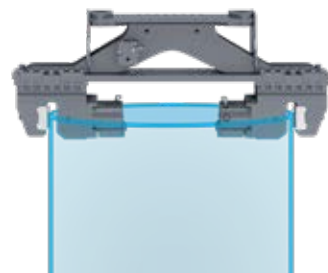

SIDE GRIP PILE VIBRATORY DRIVERS

BOTTOM CLAMP incl. options

Models SG-80VA/F

The (standard) bottom clamp is utilised for the completion of the pile driving and is suitable for all kinds of piles including sheet piles, H-beams and tubular steel piles.

The bottom clamp is equipped with pads for the specific pile type in question, Sheet pile pads are utilised for sheet piles and H-beams, Double (sheet) pile pads are recommended when driving double sheet piles (both U and Z). Tube pads are available in two sizes, from OD 323,9 mm to 508 mm and OD 508 mm to OD 762 mm; both covering the entire range as specified.

Smaller OD tube piles (from 88,9 mm to 323,9 mm and timber piles require a top hitter. The same top hitter is suitable for the entire range.

An optional handling jaws can be provided for added pile handling capabilities.



Lifting lever

The bottom clamp is equipped with a lifting lever for handling of sheet piles.

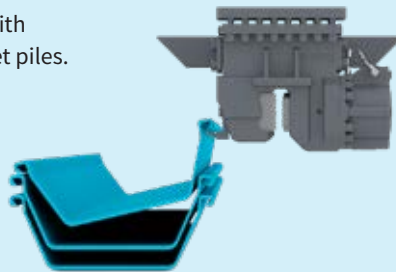

Top hitter (optional)

Smaller OD tube piles and timber piles require a top hitter. The same top hitter is suitable for the entire range.

Top hitters for larger OD piles and f. ex. square timber piles are available by request.



Sheet pile pads



Tube pads
OD 323,9...508 mm
OD 508...762 mm



Double (sheet)
pile pads
Available for double-Z
type sheet piles



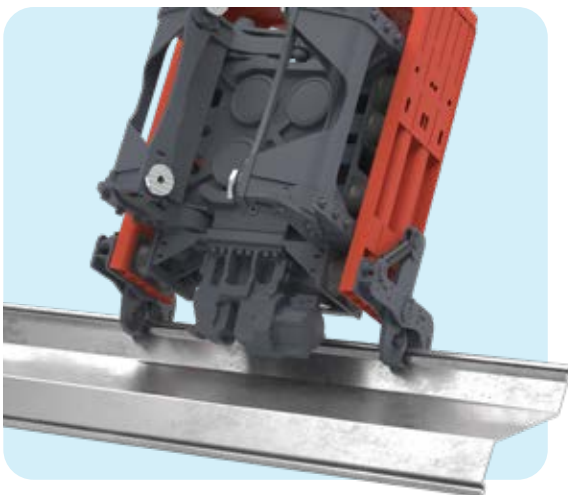

Handling jaws (optional)

Handling jaws are available with different type of inserts for optimised gripping of different type of pile profiles (both sheet piles and smaller OD tube pile piles).

SIDE GRIP VIBRATORY PILE DRIVERS

TECHNICAL DATA

Models SG-80VA/F

Model		SG-80VA	SG-80F
Weight w/ sheet pile clamps, excl adapter	kg	3200	3100
Height	mm	2860	2860
Depth	mm	1295	1295
Width	mm	1230	1230
Frequency	1/min	2300-3000	
Eccentric moment	kgm	8,1	8,1
Centrifugal force, max	kN	800	800
Ground vibration		minimal	normal
Resonance-free start/stop		yes	no
Driving method		vibration	
Swing/tilt angle	o	360/±45	360/±45
Return pressure, max	bar	5	5
Pressure setting	bar	350	350
Excavator class	t	33-50	33-50
Engine power, min. TIER III	kW	180	180
Engine power, min. TIER IV	kW	200	200

Suitable piles

Length & weight	m/kg	6 / 2800 12 / 1900 16 / 1300
Sheet piles, width	mm	400-1200
Sheet piles, max. depth	mm	265
H-beams	size	H100-H500
Timber piles	mm	Ø160-420, Ø430-600
Tubular steel piles, tubes	mm	Ø88,9-762, Ø508-1220





SIDE GRIP VIBRATORY PILE DRIVERS

MOVAX MODULAR SYSTEM

Models SG-45(V) to SG-60(V)

The MOVAX Modular System (MMS™) enables the use of the same MOVAX side grip pile driver for a wide range of different type of piles ranging from sheet piles, H-beams and tubular steel piles to timber piles. The MOVAX Modular System includes interchangeable arms, clamps and pads that can easily and efficiently be changed for the different pile types in question.

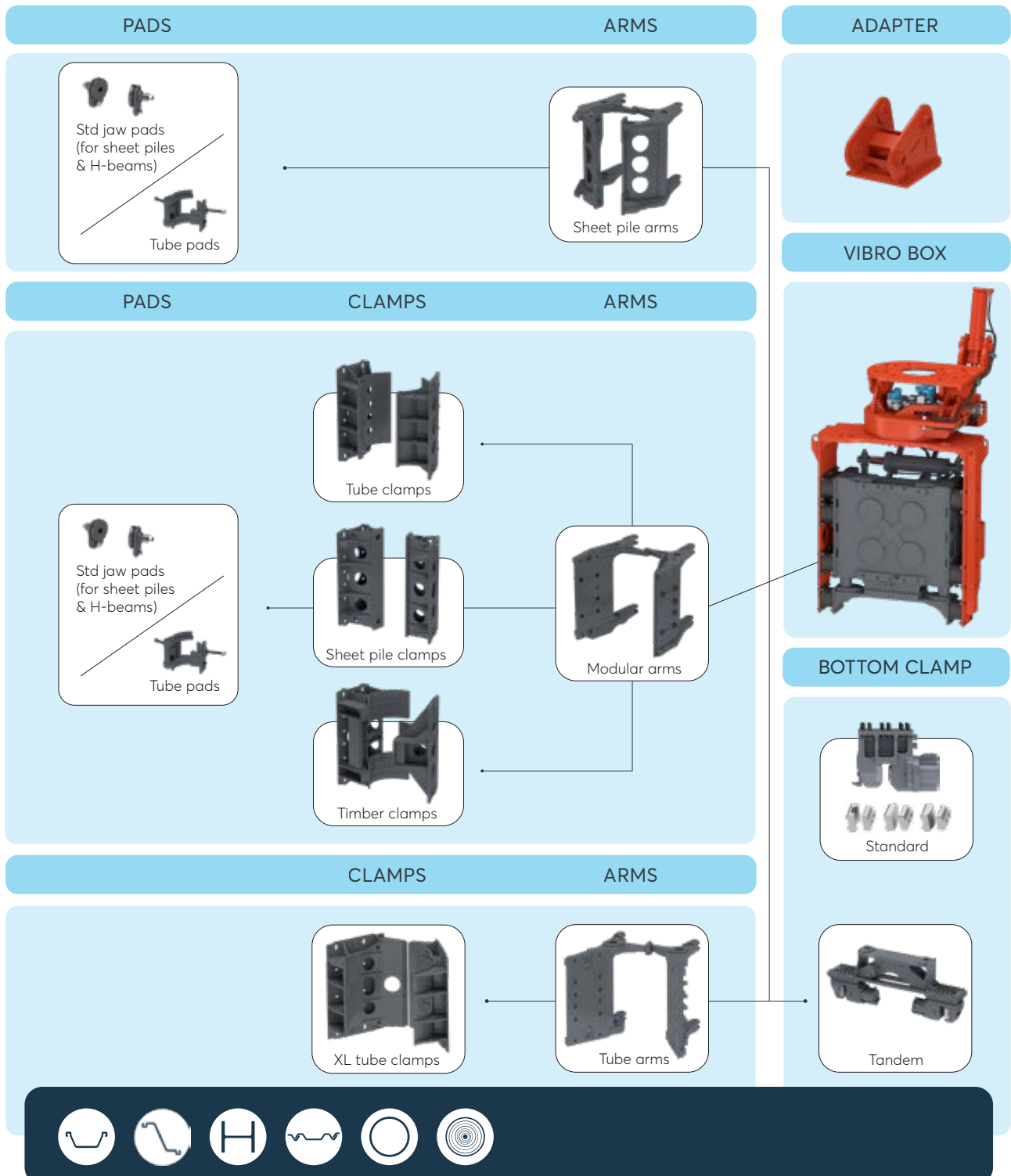

SIDE GRIP VIBRATORY PILE DRIVERS

MOVAX MODULAR SYSTEM

Models SG-45(V) to SG-60(V)

SHEET PILE ARMS

SHEET PILE CLAMPS



MODULAR ARMS

SHEET PILE CLAMPS

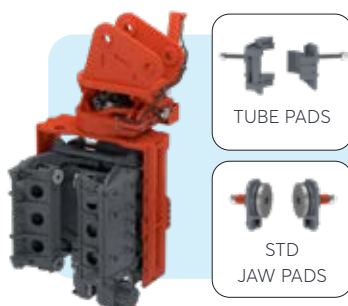

TUBE CLAMPS



TIMBER CLAMPS



TUBE ARMS

XL TUBE CLAMPS



SIDE GRIP VIBRATORY PILE DRIVERS

SHEET PILE ARMS

Models SG-45(V) to SG-60(V)

Special sheet pile arms are the optimum solution when handling, pitching, driving and extracting only – or mainly – sheet piles and/or H-beams.

The special sheet pile arms can also be utilised to drive smaller diameter tubular steel piles or micropiles up to OD 273 mm. Each tubular steel pile size requires its own, individual tube pads.



SHEET PILE PADS
for sheet piles and H-beams

Standard sizes
w 400–1200 mm
/ H180–H500



TUBE PADS
for tubular steel piles
from OD 88.9 mm to OD 273 mm

Standard sizes

Ø 88.9	Ø 127	Ø 219.1
Ø 101.6	Ø 139.7	Ø 273
Ø 114.3	Ø 168.3	

Customised sizes and special types, for instance for rail tracks, are available by request.

SHEET PILE ARMS are designed for the optimum handling, pitching and driving/extraction of sheet piles, H-beams and tube piles.



Clamp hooks



Clamping the web



Handling, pitching,
driving & extracting
H-beams



Handling, pitching,
driving & extracting
sheet piles



Handling, pitching,
driving & extracting
small OD tube piles



SIDE GRIP VIBRATORY PILE DRIVERS

TUBE ARMS

Models SG-45(V) to SG-60(V)

Special modular tube arms are utilised to handle and drive large diameter tubes from 508 mm up to OD 1220 mm. Each tube size requires its own tube clamp in order to ensure proper operation.

A tandem bottom clamp is available for the same tube sizes as the tube arms for optimised pile driving of large tubes.



TUBE CLAMPS
for tubular steel piles from
OD 508 mm to OD 1220 mm

Standard sizes

Ø 508	Ø 762	Ø 1016
Ø 610	Ø 813	Ø 1220
Ø 711	Ø 914	

Customised sizes are available by request.

**TANDEM
BOTTOM CLAMP**



TUBE PADS

Standard sizes

Tube pads for tandem
bottom clamp from
OD 508 mm up to
OD 1220 mm



TUBE ARMS are designed for the optimum handling, pitching and driving/extraction of large OD tubes.



Handling, pitching,
driving & extracting
large OD tube piles

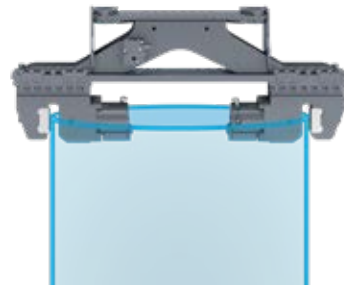

Tandem bottom clamp
driving/extracting
large OD tube piles



SIDE GRIP VIBRATORY PILE DRIVERS

MODULAR ARMS

Models SG-45(V) to SG-60(V)

Modular arms are suitable for driving sheet piles, H-beams, tubular steel piles and timber piles.

Sheet pile clamps are utilised to drive sheet piles and H-beams. The sheet pile clamps can be equipped with tube pads for tubular steel piles up to OD 273 mm. Each tube size requires its own tube pads in order to ensure proper operation.

Tube clamps are utilised for tubular steel piles up to OD 762 mm. Each tube size requires also its own tube clamps.

Timber clamps are utilised to drive timber or wooden piles. A range of round timber piles can be driven with the same timber clamps whereas square timber piles requires clamps of the same size.

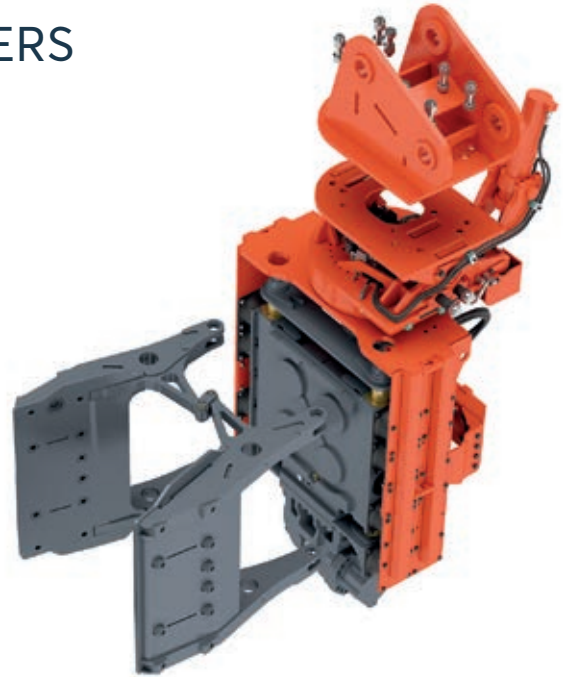



TUBE CLAMPS

for tubular steel piles from
OD 88.9 mm up to OD 762 mm:

Standard sizes

Ø 88.9	Ø 168.3	Ø 457
Ø 101.6	Ø 219.1	Ø 508
Ø 114.3	Ø 273	Ø 610
Ø 127	Ø 323.9	Ø 711
Ø 139.7	Ø 406.4	Ø 762



SHEET PILE CLAMPS

for sheet piles and H-beams/
tubular steel piles from OD 88.9 mm
to OD 273 mm:

SHEET PILE PADS

w 400–1200 mm/H180–H500



TUBE PADS

Standard sizes

Ø 88.9	Ø 139.7
Ø 101.6	Ø 168.3
Ø 114.3	Ø 219.1
Ø 127	Ø 273

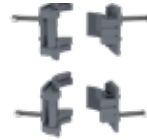

TIMBER CLAMPS

for timber piles from
OD 160 mm up to 600 mm:

A range of round timber pile sizes
can be driven with the same
timber clamps.

Standard sizes

M Ø 160–420 mm
L Ø 430–600 mm

In addition clamps for square
timber piles are also available.
Each square timber pile size
requires clamps of matching size.

Customised sizes are available by request. (e.g. clamps for square timber piles or other special profiles).

MODULAR ARMS are designed for versatility and to handle, pitch, drive and extract
sheet piles, tube piles or timber piles.



Handling, pitching,
driving & extracting
tube piles



Handling, pitching,
driving & extracting
sheet piles



Handling, pitching,
driving & extracting
small OD tube piles



Handling, pitching,
driving & extracting
timber piles



SIDE GRIP VIBRATORY PILE DRIVERS

BOTTOM CLAMP incl. options

Models SG-45(V) to SG-60(V)

The (standard) bottom clamp is utilised for the completion of the pile driving and is suitable for all kinds of piles including sheet piles, H-beams and tubular steel piles.

The bottom clamp is equipped with pads for the specific pile type in question, Sheet pile pads are utilised for sheet piles and H-beams, Double (sheet) pile pads are recommended when driving double sheet piles (both U and Z). Tube pads are available in two sizes, from OD 323,9 mm to 508 mm and OD 508 mm to OD 762 mm; both covering the entire range as specified.

Smaller OD tube piles (from 88,9 mm to 323,9 mm and timber piles require a top hitter. The same top hitter is suitable for the entire range.

An optional 4th jaw can be provided for added pile handling capabilities.



Top hitter (optional)

Smaller OD tube piles (from 88,9 mm to 323,9 mm and timber piles require a top hitter. The same top hitter is suitable for the entire range.



Top hitters for larger OD piles and f. ex. square timber piles are available by request.

Lifting lever

The bottom clamp is equipped with a lifting lever for handling of sheet piles.

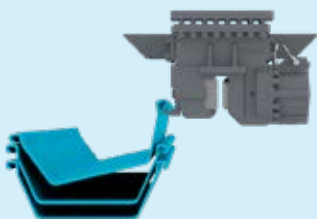

4th jaw (optional)

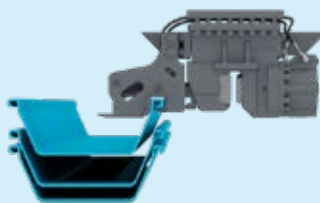

Sheet pile pads



Tube pads
OD 323,9...508 mm
OD 508...762 mm



Double (sheet)
pile pads
Available for double-Z
type sheet piles



SIDE GRIP VIBRATORY PILE DRIVERS

TECHNICAL DATA

Models SG-45(V) - SG-60(V)

Model		SG-60V	SG-50V	SG-45V	SG-60	SG-50	SG-45
Weight	kg	2650-2950	2500-2800	2490-2790	2550-2850	2400-2700	2390-2690
Height	mm	2550	2530	2530	2550	2530	2530
Depth	mm	1180-1436	1180 - 1436	1180-1436	1180-1436	1180-1436	1180-1436
Width	mm	1193	1193	1193	1193	1193	1193
Frequency	1/min	2300-3000	2300-3000	2300-3000	2300-3000	2300-3000	2300-3000
Eccentric moment	kgm	6,1	5,1	4,6	6,1	5,1	4,6
Centrifugal force, max	kN	600	500	450	600	500	450
Ground vibration		low			normal		
Resonance-free start/stop		yes			no		
Driving method		vibration					
Swing/tilt angle	°	360/30	360/30	360/30	360/30	360/30	360/30
Return pressure, max	bar	5	5	5	5	5	5
Pressure setting	bar	350	350	350	350	350	350
Excavator class	t	28-32	23-28	20-24	28-32	23-28	20-24
Engine power, min. TIER III	kW	135	117	100	135	117	100
Engine power, min. TIER IV	kW	160	135	120	160	135	120

Suitable piles

Length & weight	m/kg	8 x 2300	8 x 2300	8 x 2300	8 x 2300	8 x 2300	8 x 2300
		12 x 1800	12 x 1800	12 x 1800	12 x 1800	12 x 1800	12 x 1800
		16 x 1200	16 x 1200	16 x 1200	16 x 1200	16 x 1200	16 x 1200
Sheet piles, width	mm	400-1200					
Sheet piles, max. depth	mm	265					
H-beams	size	H100-H500					
Timber piles	mm	Ø160-420					
Tubular steel piles, tubes	mm	Ø430-600					





SIDE GRIP VIBRATORY PILE DRIVERS

MOVAX MODULAR SYSTEM

Models SG-15N to 40N

The MOVAX Modular System (MMS™) enables the use of the same MOVAX side grip pile driver for a wide range of different type of piles ranging from sheet piles, H-beams and tubular steel piles to timber piles.

The MOVAX Modular System includes interchangeable clamps and pads that can easily and efficiently be changed for the different pile types in question.

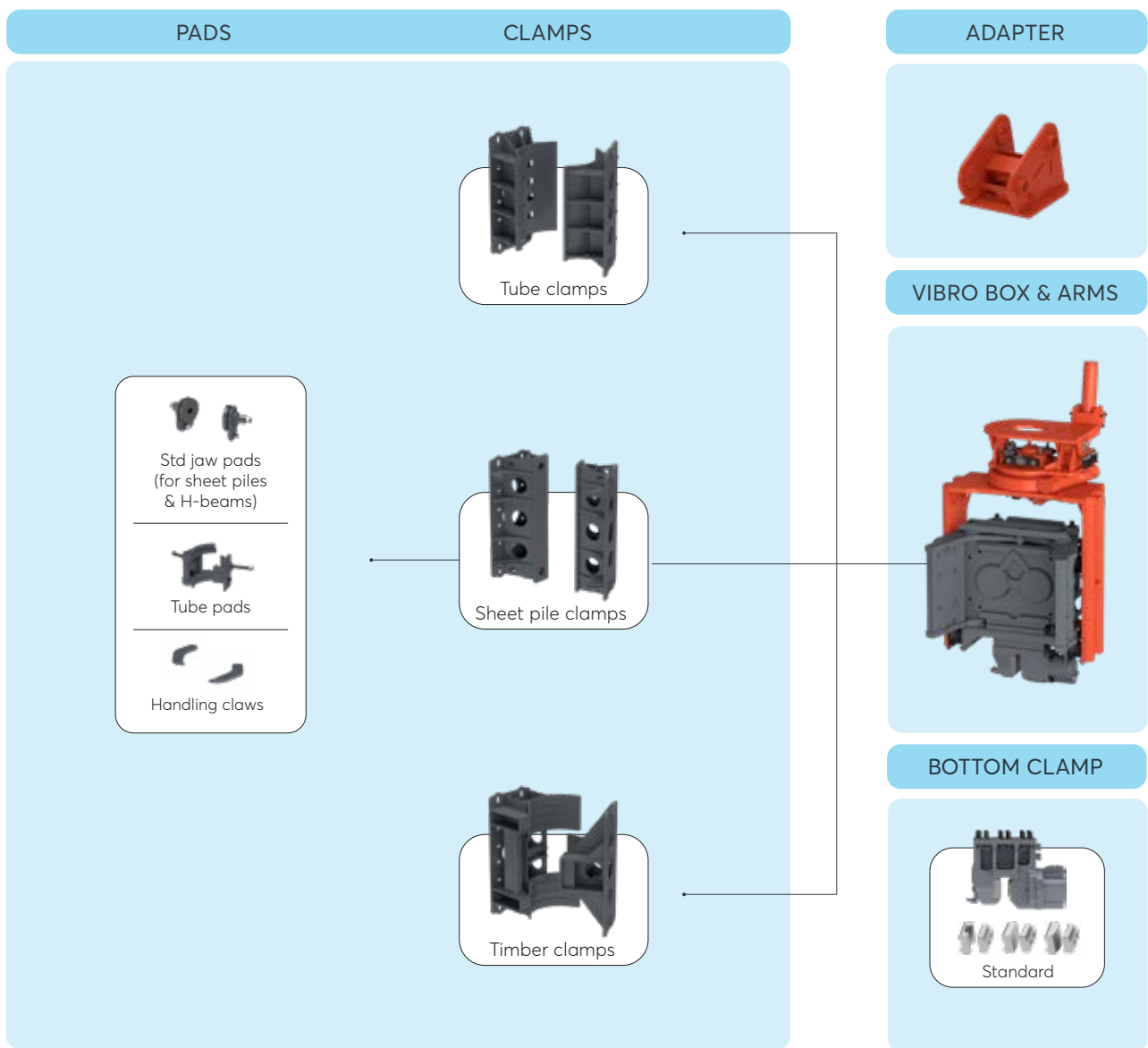

SIDE GRIP VIBRATORY PILE DRIVERS

MOVAX MODULAR SYSTEM

Models SG-15N to 40N

MODULAR ARMS

SHEET PILE CLAMPS

TUBE CLAMPS

TIMBER CLAMPS



SIDE GRIP VIBRATORY PILE DRIVERS

MODULAR ARMS

Models SG-15N to 40N

Modular arms are suitable for driving sheet piles, H-beams, tubular steel piles and timber piles.

Sheet pile clamps are utilised to drive sheet piles and H-beams. The sheet pile clamps can be equipped with tube pads for tubular steel piles up to OD 273 mm. Each tube size requires its own tube pads of matching size in order to ensure proper operation.

Tube clamps are utilised for larger tubular steel piles. Each tube size requires also its own tube clamps.

Timber clamps are utilised to drive timber or wooden piles. A range of round timber piles can be driven with the same timber clamps whereas square timber piles requires clamps of the same size.

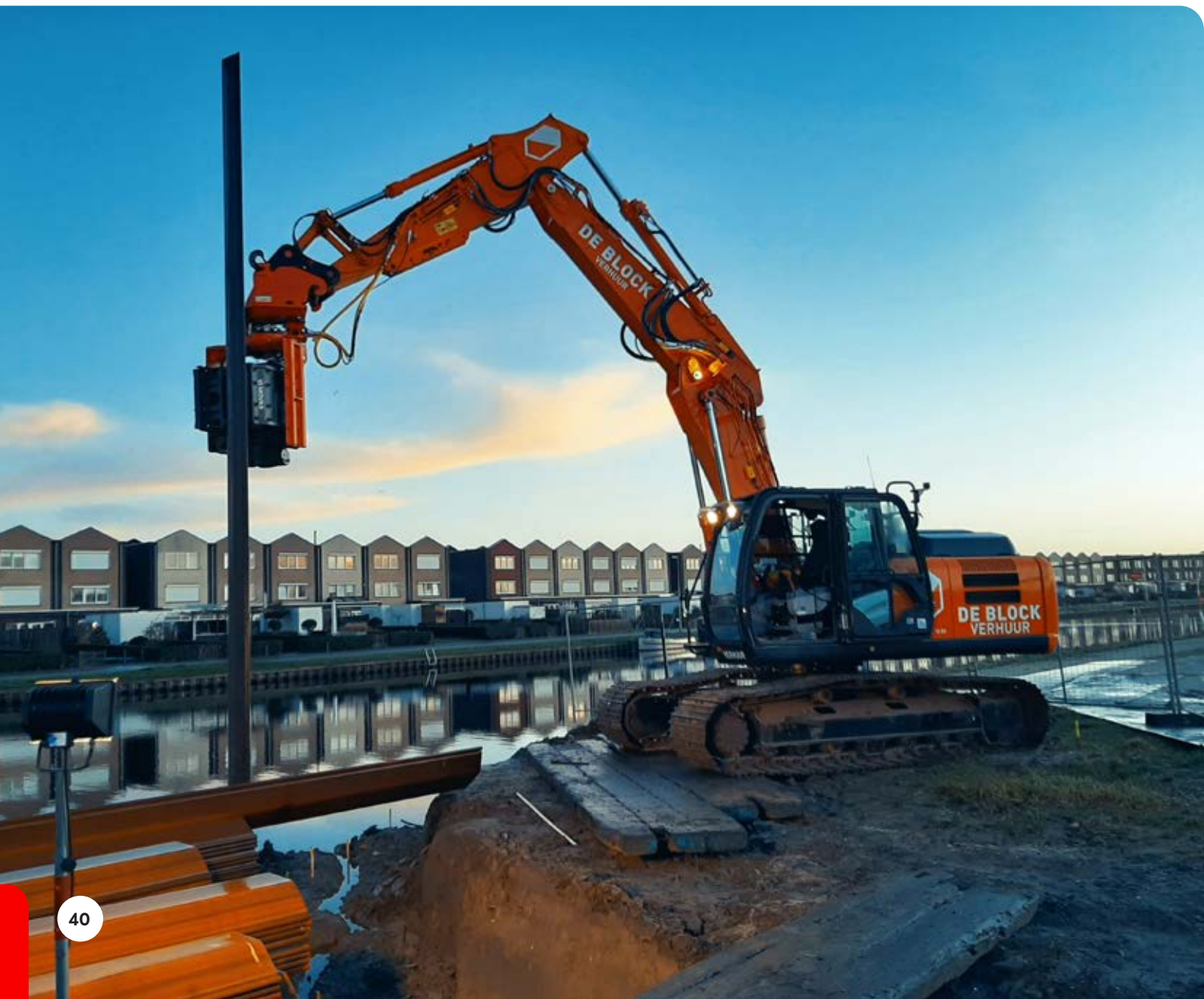

SIDE GRIP VIBRATORY PILE DRIVERS

MODULAR ARMS

Models SG-15N to 40N



TUBE CLAMPS

for tubular steel piles from
OD 88.9 mm up to
OD 323.9/508 mm:

SG-30N...SG-40N

Ø 88.9–508 mm

SG-15N

Ø 88.9–323.9 mm

Standard sizes

Ø 88.9	Ø 168.3
Ø 101.6	Ø 219.1
Ø 114.3	Ø 273
Ø 127	Ø 323.9
Ø 139.7	Ø 406.4
Ø 457	Ø 508



SHEET PILE CLAMPS

for sheet piles and H-beams and
tubular steel piles from OD 88.9 mm
to OD 273 mm:

SHEET PILE PADS

SG-30N...SG-40N

w 400–1200 mm/H120-H400

SG-15N

w 400–600 mm/H120-H140



TUBE PADS

Standard sizes

Ø 88.9	Ø 139.7
Ø 101.6	Ø 168.3
Ø 114.3	Ø 219.1
Ø 127	Ø 273



HANDLING CLAWS



TIMBER CLAMPS

for timber piles from
OD 100/120 mm up to
OD 300/325 mm:

A range of round timber pile sizes
can be driven with the same
timber clamps.

Standard sizes

SG-30N & SG-40N

S Ø 120-250 mm

M Ø 220-325 mm

SG-15N

S Ø 100-200 mm

M Ø 200-300 mm

In addition clamps for square
timber piles are also available.
Each square timber pile size
requires clamps of matching size.

Customised sizes are available by request. (e.g. clamps for square timber piles or other special profiles).

MODULAR ARMS are designed for versatility and to handle, pitch, drive and extract sheet piles, tube piles or timber piles.



Handling, pitching,
driving & extracting
tube piles



Handling, pitching,
driving & extracting
sheet piles



Handling, pitching,
driving & extracting
small OD tube piles



Handling, pitching,
driving & extracting
timber piles



SIDE GRIP VIBRATORY PILE DRIVERS

BOTTOM CLAMP incl. OPTIONS

Models SG-15N to 40N

The (standard) bottom clamp is utilised for the completion of the pile driving and is suitable for all kinds of piles including sheet piles, H-beams and tubular steel piles, as well as timber piles.

The bottom clamp is equipped with pads for the specific pile type in question, Sheet pile pads are utilised for sheet piles and H-beams, Double (sheet) pile pads are recommended when driving double sheet piles (both U and Z). Tube pads are available from OD 323,9 mm to 508 mm; covering the entire size range as specified.

Smaller OD tube piles and timber piles require a top hitter. The same top hitter is suitable for the entire range.



Top hitter (optional)

Smaller OD tube piles (from 88,9 mm to 323,9 mm and timber piles require a top hitter. The same top hitter is suitable for the entire range.



Top hitters for larger OD piles and f. ex. square timber piles are available by request.

Lifting lever (SG-30N, SG-40N only)

The bottom clamp is equipped with a lifting lever for handling of sheet piles.

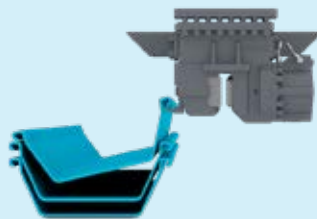

Sheet pile pads



Tube pads*
OD 323,9...508 mm



Double (sheet) pile pads*
Available for double-Z type sheet piles

* Available for SG-30N & SG-40N.





SIDE GRIP VIBRATORY PILE DRIVERS

TECHNICAL DATA

Models SG-15N to 40N

Model		SG-40N	SG-30N	SG-15N
Weight	kg	1505	1485	760
Height	mm	2042	2042	1500
Depth	mm	1138	1138	900
Width	mm	1030	1030	850
Frequency	1/min	2300-3000	2300-3000	2300-3000
Eccentric moment	kgm	4,1	3,1	1,6
Centrifugal force, max	kN	400	300	150
Ground vibration		normal		
Resonance-free start/stop		no		
Driving method		vibration		
Swing/tilt angle	o	360/30	360/30	360/30
Return pressure, max	bar	5	5	5
Pressure setting	bar	350	350	300
Excavator class	t	17-21	13-16	7-12
Engine power, min. TIER III	kW	85	65	38
Engine power, min. TIER IV	kW	90	70	38

Suitable piles

Length & weight	m / kg	6 / 1200 8 / 1000 10 / 900	4 / 400 6 / 200
Sheet piles, width	mm	400-1200	400-600
Sheet piles, max. depth	mm	260	140
Trench sheets	mm	330-600	
H-beams	size	H100-H400	H100-H140
Timber piles	mm	Ø220-325	Ø200-300
Tubular steel piles, tubes	mm	Ø88,9-508	Ø88,9-323,9







INTRODUCTION

PILING HAMMER TECHNOLOGY

MOVAX Piling Hammers are hydraulic, double acting impact-type, piling hammers utilised for driving load-bearing piles or assisting in sheet pile driving in even the most difficult soil conditions.

MOVAX piling hammers can be utilised to complete a pile installation after reaching refusal with a side grip pile driver or when load testing is required. MOVAX piling hammers can further be utilised independently for driving a wide range of piles including sheet piles, H-beams, tubular steel piles, timber piles or pre-cast concrete piles.

MOVAX piling hammers are excavator mounted – either directly mounted onto the excavator, or in connection with an excavator mounted piling leader. As the MOVAX piling hammers utilize the hydraulic power of the excavator as its driving force no external sources of energy such as power packs are needed.

Hydraulic, double-acting piling hammer

MOVAX hydraulic piling hammers uses the hydraulic energy produced by the excavator to lift the ram of the piling hammer to the desired elevation. When the piling hammer is released from its desired drop height the potential energy is then translated into the corresponding kinetic energy. This kinetic energy is utilized to drive the pile. External energy is added to the potential energy with the hydraulics of the excavator in order to overcome friction etc losses. Hence the definition 'double-acting'.

The working cycle is as follows: lift ram, release/drop ram, re-lift ram aso. Both the drop height and the blow count can be flexibly adjusted based on the pile and piling requirements thus precisely controlling the energy utilized (as required) for the pile driving.

The ram velocity prior to impact is measured and the operator can monitor the impact energy with the MOVAX control system.

The efficiency of the MOVAX piling hammer is high, > 95%.

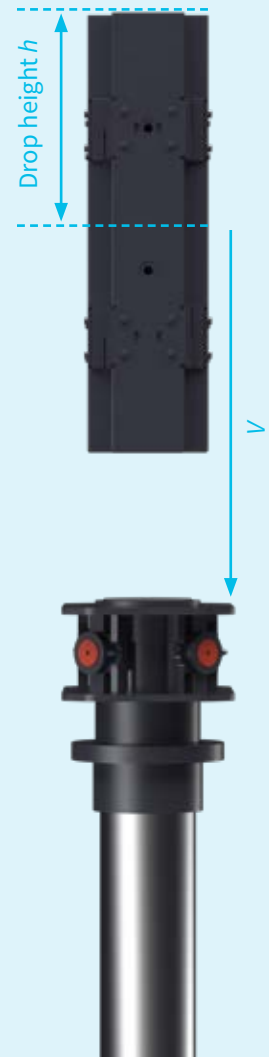
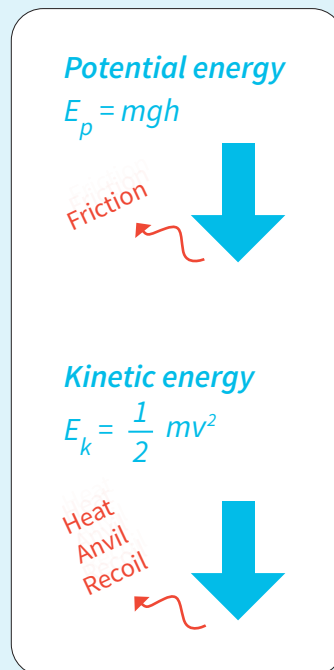



PILING HAMMERS

FEATURES

EXCAVATOR-MOUNTED

- Suitable for 20-50 ton excavators.
- Utilizing the hydraulic power and lifting capacity of the excavator or rail roader (carrier).
- Designed to work on any and all wheeled and crawler-type excavators and rail roaders by utilising and commanding the standard auxiliary hydraulics and/or by connecting to the electronic control of the excavator.

COMPREHENSIVE MODEL & SIZE RANGE

- Available in different models, sizes and configurations for different piling requirements and different type of piles ranging sheet piles and H-beams to tubular steel piles, precast concrete piles and timber piles.
- Available for excavators ranging from 20 to 50 ton – thus always ensuring the optimum size and correct combination of piling hammer and excavator.

DOUBLE ACTING, IMPACT TYPE TECHNOLOGY

- Drop height controlled between 1-1,2 m
- Blow count controlled between 1-100 blows per minute

VERSATILE OPTIONS

- Tilt device with +/- 15° tilt.
- Bolt-on plate mounted tilt (+/- 15°) & rotation device (+/- 60°) for optimum sheet pile driving (*note! models DH-15 and DH-25, only*).
- Available with 2,5 ton capacity pile handler for handling of different type of piles. Pile handler can be retrofitted on an existing MOVAX piling hammer.
- The same MOVAX piling hammer can be used on different carriers; mounting options include excavator-, MOVAX multi-tool piling leader-, (third party) piling rig- or crane.

MOVAX MODULAR SYSTEM

- Versatility based on the MOVAX Modular System™ which enables the use of the same unit for a wide range of different piling requirements and type of piles. The modular system includes a wide range of pile caps.

MOVAX CONTROL SYSTEM

- Controlled with the MOVAX Control System, mControl+ LITE or PRO

MOVAX INFORMATION MANAGEMENT SYSTEM

- mFleetManagement for monitoring MOVAX piling equipment operation, performance and condition.
- Optional mLogbook for monitoring and reporting the piling works including pile set criterion.



DRIVING LOAD BEARING PILES & ASSISTING IN SHEET PILE DRIVING



PILING HAMMERS

MOUNTING OPTIONS

The MOVAX piling hammers can be mounted directly onto the excavator (stick), onto MOVAX Multi-tool piling leader, or a third-party piling rig or crane.



Excavator-mounted



MOVAX multi-tool piling leader-mounted

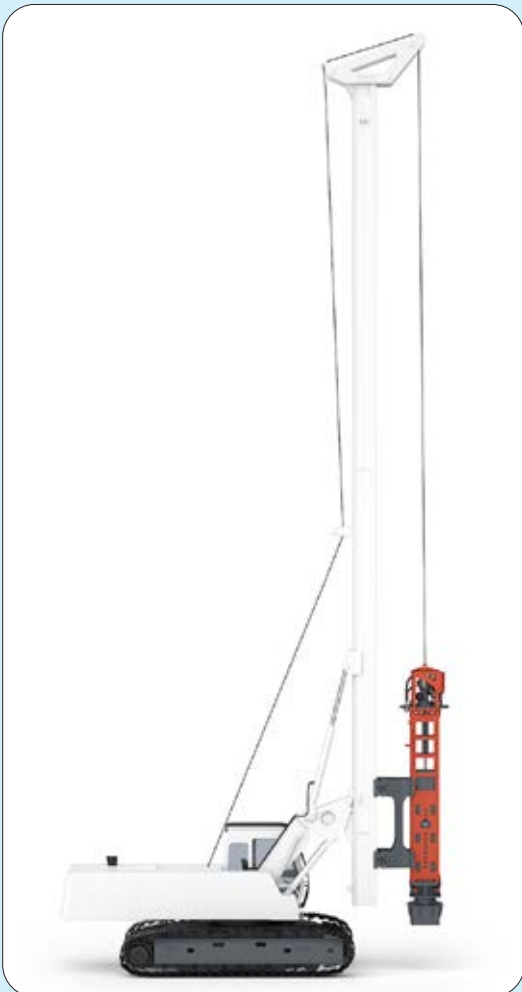

Piling rig-mounted



Crane-mounted

Due to the modular design the same MOVAX piling hammer can be used on all the various carriers with minimum modifications. The mounting bracket, top cover and lower frame must be selected in accordance with the mounting option.

MOUNTING BRACKET

Each mounting option requires its own mounting bracket (except crane-mounting which do not require a mounting bracket).



Excavator-mounted



MPL-mounted



Piling rig-mounted

TOP COVER

The top cover is the same for the excavator- and multi-tool piling leader (MPL)- mounted DH piling hammer. When mounting the DH on a third party piling rig or on a crane a top cover with lifting lugs is required.



Excavator- & MPL-mounted



Piling rig-/crane-mounted

LOWER FRAME

The lower frame is the same for the excavator-, multi-tool piling leader (MPL)- and piling rig-mounted DH piling hammer. The crane-mounted piling hammer is equipped with a pile sleeve ("bell") with pile guides available separately for tubular steel piles and sheet piles.



Excavator-, MPL- & piling rig-mounted



Crane mounted (with Bell)



PILING HAMMERS

PILE HANDLER

The MOVAX DH piling hammers can be equipped with a pile handler for added pile handling capabilities. The pile handler can also be added to existing MOVAX DH piling hammers by simply changing the top cover and adding the pile handler winch and guide.



TECHNICAL DATA

Technical data		
Lifting capacity	kg	2500
Wire rope length	m	36
Total weight	kg	160





PILING HAMMERS

SELECTION

The suitable MOVAX piling hammer-model is selected based on the soil & site conditions, the excavator and the main dimensions (weight & length) of the piles to be driven. The configuration is then defined by the type of piles.

Excavator (carrier)

The excavator must be suitable – and match – the specific piling hammer in question in regards to hydraulic power (oil flow @ pressure) and have the sufficient handling capacity for stable operation. Thus the excavator brand & model is needed for the correct selection of model.

Mounting options

The same MOVAX piling hammer can be used on different carriers; mounting options include excavator-, MOVAX multi-tool piling leader-, (third party) piling rig- or crane. For the suitability of mounting onto MOVAX multi-tool piling leaders refer to the Product Catalogue section in question. The suitability of a MOVAX piling hammer for third party piling rig or crane installation shall always be checked by MOVAX.

Site and soil conditions

Piling hammers are suitable for a wide range of sites and soil conditions (N-values/SPT). In order to make a detailed analysis of the suitability of a MOVAX model for a specific project a soil report is needed.

Type & dimension of piles

In order to select the correct MOVAX model, the type of piles (sheet pile, H-beam, tubular steel pile, precast concrete and/or timber pile) and their dimensions (length, width/depth, OD) are needed. Due to the modular design the same MOVAX piling hammer can be used to drive different type of piles.

SELECTION CHART

EXCAVATOR CLASS	(38) 40-50 ton	(33) 35-50 ton	(28) 30-50 ton	(20) 23-50 ton
PILE SIZE (length/weight)				
Max. pile length and weight based on excavator reach and stability.	DH-45	DH-35	DH-25	DH-15
SUITABLE PILES				
Sheet piles	width 400-700 mm			
H-beams	H180-H700		H180-H500	
Precast concrete piles (max)	508 mm x 508 mm			
Timber piles	Ø 90-510 mm			
Tube piles	Ø 88.9-1200 mm		Ø 88.9-762 mm	

NOTE!

Preliminary. When making the final selection the excavator engine size and hydraulic system design (oil pump arrangement, oil flow rate/pressure etc), excavator lifting capacity and stability and soil and site conditions shall be taken into account.

PILING HAMMERS

PILE CAPS

MOVAX piling hammers can be equipped with the following standard type of pile caps (customized pile caps are available upon request):

SHEET PILES / H BEAMS



DH-15, DH-25, DH-35 and DH-45 (S)

for PU and GU sheet piles 600 mm /
H-beam < 500 mm



DH-15, DH-25, DH-35 and DH-45 (M)

for AU sheet piles > 700 mm / H-beams < 700 mm

TUBULAR STEEL PILES, MICROPILES



DH-15 and DH-25

XS Ø 88,9–273 mm



DH-35 and DH-45

XS Ø 88,9–323,9 mm

TUBULAR STEEL PILES

Tubular steel pile caps are supplied with an external guide (as a standard, unless otherwise requested).

Flat type pile cap and pile cap with internal guide are available by request.

S Ø 273-508 mm
M Ø 406,4-762 mm
L Ø 762-1220 mm



External guide (Standard)

Available by request:



Flat



Internal guide

PRE-CAST CONCRETE PILES



XS 225 x 225 mm L 350 x 350 mm
S 250 x 250 mm XL 450 x 450 mm
M 300 x 300 mm

Customised, pile caps are available from 180 x 180 mm to 508 x 508 mm.

TIMBER PILES



DH-15, DH-25

Round

XS Ø 90–220

S Ø 220–510

Square

XS 225 x 225 mm

S 250 x 250 mm

M 300 x 300 mm

L 350 x 350 mm



DH-35, DH-45

Round

XS Ø 90–325

S Ø 270–510

Square

XS 225 x 225 mm

S 250 x 250 mm

M 300 x 300 mm

L 350 x 350 mm

NOTE! A single pile cap can handle the given range.

PILING HAMMERS

TECHNICAL DATA

The MOVAX DH-25 model is designed so that a modular ram/frame extension assembly can be added enabling the use of the same DH-25 piling hammer with a ram weight of 3 tons.

Model		DH-45	DH-35	DH-25	DH-15
Total weight*	kg	6700	5750	4400**/4700*** 5750**/6050*** w/ ram extension	3500**/3800***
Ram weight	kg	4000	3100	2060/3000 w/ ram extension	1360
Blows per minute	1/min	0-100	0-100	0-100	0-100
Impact energy	kNm	0-45	0-35	25-35	0-15
Drop height	m	0-1,2	0-1,2	0-1,2	0-1,2
Pressure relief set, max.	bar	350	350	350	350
Operating pressure	bar	280	250	200-250	150
Oil flow rate	l/min	80-120	80-120	80-120	80-120
Tilt angle	°	+/-15	+/-15	+/- 15	+/-15
Rotation angle	°	N/A	N/A	+/-60	+/-60
Leader	m	1,3	1,3	1,3	0,7
Leader, type		floating	floating	floating	floating
Total height	mm	4930	4460	4460 5310 w/ ram extension	3850
Frame width	mm	650	650	500	500
Transport width	mm	1200	1200	1200	1200
Transport depth	mm	1870	1870	1870	1870
Excavator class	t	(38)-50	(33)-50	(28-33)-50	(20)-50

NOTE!

* excluding adapter

** with tilt

*** with tilt+rotate

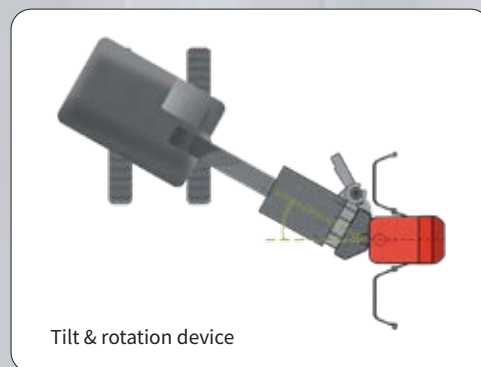
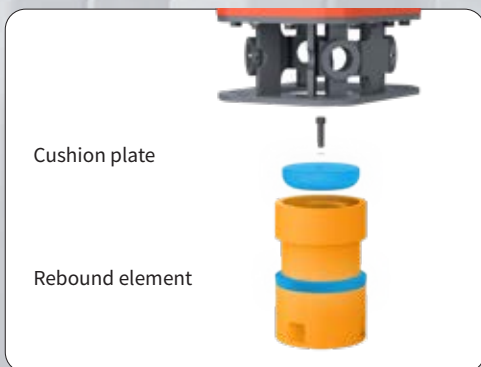



INTRODUCTION

PILING DRILL TECHNOLOGY

MOVAX Piling drills are excavator-mounted, telescopic/kelly bar-type auger drive attachments for cast in-situ (concrete) piling and other soil removal tasks.

MOVAX Piling drills are explicitly designed for soil removal tasks. MOVAX piling drills are especially suitable for work in confined spaces while still being good at reaching over obstacles. The telescopic/kelly bar design keeps the drill height low and allows working on sites with limited headroom without compromising on drilling depth.

MOVAX piling drills are operated by transferring the torque and crowd force from a rotary drive tool to the drilling tool. MOVAX utilises two different designs: a telescopic design (TAD-models) and a kelly bar design (KB-models).

Kelly bar piling drill technology

MOVAX kelly bar-design piling drills utilize interlocking-type kelly bars which have drive ribs welded with lock devices utilized to transfer the maximum amount of torque to each section. The standard kelly bars are manufactured as a fully lockable system with a mechanical locking mechanism between each element, the outer bar and the rotary drive.

The kelly-bar design piling drill can also be used for cased drilling

Telescopic piling drill technology

MOVAX telescopic-design piling drills are cylinder/chain driven. The piling drills consists of one or two moving sections.







PILING DRILLS

FEATURES

EXCAVATOR-MOUNTED

- Suitable for 20-50 ton excavators.
- Utilizing the hydraulic power and lifting capacity of the excavator or rail roader
- Designed to work on any and all wheeled and crawler-type excavators and rail roaders by utilising and commanding the standard auxiliary hydraulics and/or by connecting to the electronic control of the excavator.

TELESCOPIC

- Light weight, telescopic type piling drills with a maximum drilling depth of 9 meters intended primarily for basic rail roaders and smaller excavators.

KELLY BAR

- Heavy duty, kelly bar type piling drills with a maximum drilling depth of 20 meters intended primarily for heavy duty rail roaders and large excavators.

MOVAX MODULAR SYSTEM

- Versatility based on the MOVAX Modular System™ which enables the use of the same unit for a wide range of different piling requirements.
- The modular system includes a wide range of lead augers in different sizes and for different soil conditions.
- Available with optional service winch (KB-models, only)
- Available with optional casing adapter and cardan joint for cased drilling (KB-models, only)

MOVAX CONTROL SYSTEM

- Controlled with the MOVAX Control System, mControl+ LITE or PRO

MOVAX INFORMATION MANAGEMENT SYSTEM

- mFleetManagement for monitoring MOVAX piling equipment operation, performance and condition.
- Optional mLogbook for monitoring and reporting the piling works.

LEAD AUGERS



Heavy duty/conical



Rock/cylindrical

SERVICE WINCH



CASED DRILLING



Cardan joint



Casing adapter



CAST-IN SITU CONCRETE PILING & SOIL REMOVAL



PILING DRILLS

TECHNICAL DATA

Models KB-70L & 70S

Model		KB-70L	KB-70S
Drilling depth*	m	20	9-15
Weight**	kg	6700	5300-5800
Height**	mm	5550	4500
Oil flow rate	l/min	100-200	100-200
Oil pressure	bar	350	350
Hole diameter	mm	420-1500	420-1500
Drill speed range	rpm	10-120	10-120
Side tilt angle	°	±15	±15
Torque	kNm	70	70
Extraction force	kN	75	57
Crowd force	kN	190	190
Excavator class***		35-50	(30) 35-50

Lead augers

Model		rock or heavy duty
Outer diameter	mm	420-1500

Accessories (optional)

Service winch	2,5 ton for handling rebar or reinforcement steel
Casing adapter	tailor-made according to customer specifications
Cardan joint	tailor-made according to customer specifications

NOTE!

* drilling depth dependent on length of Kelly bar

** excluding adapter and lead auger

*** stick or boom mounted; excavator suitability to be checked





PILING DRILLS

TECHNICAL DATA

Models TAD-32 & 51

Model		TAD-32	TAD-51
Drilling depth	m	9	6
Weight*	kg	3200	3200
Height*	mm	3855	3855
Oil flow rate	l/min	75-250	75-250
Oil pressure	bar	350	350
Hole diameter	mm	400-1000	400-1000
Drill speed range	rpm	11-74	11-74
Side tilt angle	°	±30	±30
Torque	kNm	30	50
Extraction force	kN	30	60
Crowd force	kN	15	15
Excavator class**		24-35	24-35

Lead augers

Model		rock or heavy duty
Outer diameter	mm	400-1000

NOTE!

* excluding adapter and lead auger

** stick or boom mounted; excavator suitability to be checked

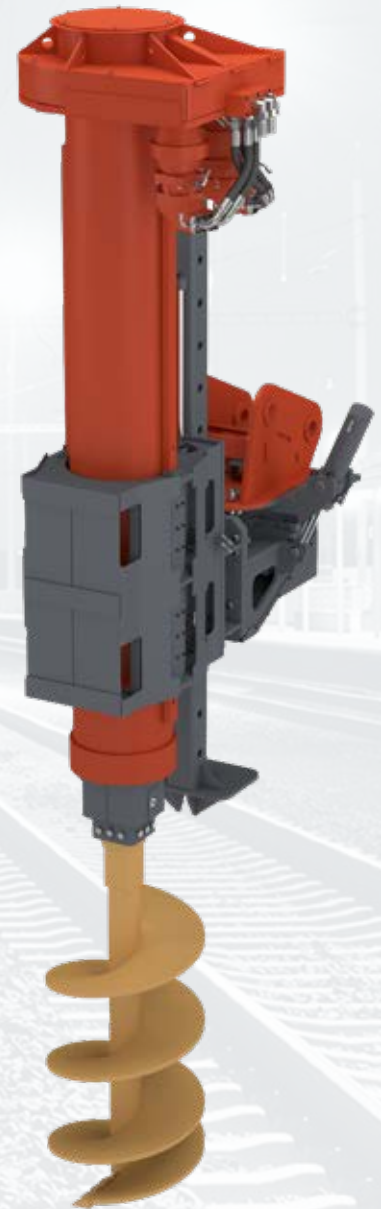





INTRODUCTION

MANIPULATORS

MOVAX excavator mounted manipulators are designed for fast, flexible and efficient handling of different kinds of masts, gantries, and poles as well as a wide range of piles. Based on the patented side grip technology, the MOVAX manipulator is designed for superior maneuverability, safety and accuracy.

Manipulator technology

The manipulator has a rotary gear for a full 360 degree continuous tilt and cylinders for a +/- 60° rotation providing unlimited and precise handling and positioning of profiles.

The manipulator is capable of handling different type of profiles ranging from double-U-, U-, H-, and I- to rectangular and tubular-shapes as well as sheet piles, tubular steel piles, timber piles and precast concrete piles. Soft gripping surfaces are available if required to efficiently prevent damaging sensitive surfaces of masts, gantries or poles.

MOVAX Manipulators are controlled with the **MOVAX Control System** for precision and accuracy, efficiency and safety:

- Easy and exact positioning with integrated inclination sensor and mControl+ (control system) display
- Smooth movements with thumb wheel operated proportional control
- Clamping pressure shown on screen
- Integrated safety lock valves on cylinders
- Safety switch for clamp opening
- Adjustable gripping force





MANIPULATORS

FEATURES

EXCAVATOR-MOUNTED

- Suitable for 20-50 ton excavators.
- Utilizing the hydraulic power and lifting capacity of the excavator or rail roader
- Designed to work on any and all wheeled and crawler-type excavators and rail roaders by utilising and commanding the standard auxiliary hydraulics and/or by connecting to the electronic control of the excavator.

MOVAX MODULAR SYSTEM

- Available for masts, poles gantries and different type of piles including sheet piles, tubular steel piles and precast concrete piles.
- Available with gripping surfaces tailor-made for the profiles to be handled; for example to prevent scratching, etc.

MOVAX CONTROL SYSTEM

- Operated and monitored with the MOVAX Control System, mControl+ for precision and accuracy.
- Integrated safety systems.
- Adjustable gripping force for galvanised poles and other sensitive profiles.



MANIPULATORS

MOVAX MODULAR SYSTEM

The MOVAX Modular System enables the use of the same Manipulator for the handling of a wide range of different type of profiles ranging from double-U-, U-, H-, and I- to rectangular- and tubular-shapes as well as sheet piles, tubular steel piles, timber piles and precast concrete piles. Gripping surfaces are available for different type of materials and surfaces.

Standard MOVAX Manipulator clamps are available for sheet piles, tubes and square sections. Also customised clamps are available upon request.



SHEET PILE CLAMPS

For sheet piles, H-beams and similar
W400–1600 mm, H100–1000 mm.



TUBE CLAMPS

For tubular steel pipes OD 88.9–1220 mm.



CUSTOM CLAMPS

For round, square, hexagonal, etc. OD up to 1220 mm.
Also for conical shapes.

With soft gripping surfaces to protect
the surface coating.



MANIPULATORS

TECHNICAL DATA

Technical data		MPM-4000
Weight (excl. adapter)	kg	1550 - 1750
Height	mm	1562
Depth*	mm	1700 - 2300
Width*	mm	960 - 1400
Rotation angle	°	+/-60
Tilting angle	°	360
Tilting torque	Nm	20000
Relief valve pressure max	bar	350
Minimum pressure required	bar	180
Required oil flow	l/min	85
Excavator class	t	18-35
Maximum working load	kg	4000

*the exact dimension depends on the selected clamp type

Suitable profiles		
Square sections and H-beams	size	H100-H1000
		100x100
		up to 650x650
Tubular/hexagonal sections	size	88,9-1220 mm
Sheet piles	size	max depth 265 mm
Timber poles and piles	size	160-420 mm



INTRODUCTION

MULTI-TOOL PILING LEADERS

MOVAX MPL multi-tool piling leaders provide an excavator mounted, versatile, multi-tool solution for a wide range of piling requirements in a variety of site and soil conditions, and for different types of piles and piling technologies ranging from driven (vibratory & impact hammer pile driving) and bored piles (CFA) to drilled (DTH) piles – as well as, stone columns and for pre-augering.

The MOVAX MPL multi-tool piling leader is customised in accordance with customer-specific requirements:

- The same MOVAX MPL multi-tool piling leader can be utilised for different piling tasks with easily and quickly changeable tools ranging from vibratory pile drivers to impact hammers and rotary drives for pre-augering, CFA and DTH.
- The leader can be shortened to allow for low head room work; or when shorter piling or augering depths are required.
- The MOVAX MPL multi-tool piling leader is designed to work on a standard excavator without any changes thus enabling the excavator to be used for other purposes according to its original design.
- The local transportation requirements are taken into account in the customisation of the multi-tool piling leader.

	MPL-400	MPL-300
Type	Heavy duty, multi-purpose piling leader	Multi-purpose piling leader
Effective piling length/drilling depth	12 m	12 m
Tools	Vibratory pile driver Impact-type piling hammer Rotary drive for pre-augers CFA	Vibratory pile driver Impact-type piling hammer Rotary drives for pre-augers CFA DTH
Mounting (excavator class)	Boom (35-50 ton)	Boom (30-50 ton) Stick (35-50 ton)
Control	mControl+ Pro	mControl+ Pro
Information management	mFleetManagement mLogbook	mFleetManagement mLogbook

NOTE!

Tailor-made leaders are available for vibratory pile driver operation up to a maximum effective pile length of 16 meters. The maximum leader length is dependent on the excavator size and stability.

MULTIPLE PILING TASKS







MULTI-TOOL PILING LEADERS

FEATURES

EXCAVATOR-MOUNTED

- Excavator mounted, heavy duty multi-tool piling leader with tooling for a wide range of piling tasks.
- Available for a wide range of excavators starting from 30 tons and larger.
 - MPL-300 for 30 ton and larger excavators
 - MPL-400 for 40 ton and larger excavators
- Boom or stick mounted based on excavator stability. Delivered with excavator- and mounting specific adapter.
- Designed to work on any and all crawler-type excavators and rail roaders by utilising and commanding the standard auxiliary hydraulics and/or by connecting to the electronic control of the excavator - with all leader and tooling related hydraulics integrated onto the leader or tooling itself.

MOVAX CONTROL SYSTEM

- Controlled with the MOVAX Control System, mControl+ PRO.

MOVAX INFORMATION MANAGEMENT SYSTEM

- mFleetManagement for monitoring MOVAX piling equipment operation, performance and condition.
- mLogbook for monitoring and reporting the piling works including pile set criterion, CFA, etc. (optional).

VERSATILE, MULTI-TOOL PILING SOLUTION

- Suitable for a wide range of piling applications, including
 - Driven piles (sheet piles, tubular steel piles, H-beams and precast concrete piles)
 - Bored piles (CFA)
 - Drilled piles (DTH)
 - Pre-augering
 - Stone columns
- A wide range of tooling, including
 - Vibratory pile drivers
 - Hydraulic hammers
 - Hydraulic double-acting piling hammers
 - Rotary drives for pre-augering
 - Rotary drives for CFA
 - Rotary drives for DTH
- The same MPL can be used with multiple tools and for different piling and foundation tasks
 - Easy and quick change of tooling
 - Leader can also be detached enabling other (original) usage of the excavator.
- Scalable to different effective pile lengths/CFA, pre-augering & stone column depths.
- Versatile range of options based on piling technology and tooling;
 - Main winch(es)
 - Service winch(es)
 - Augers and lead augers
 - Pile and auger guides
 - Star cleaners
 - etc.

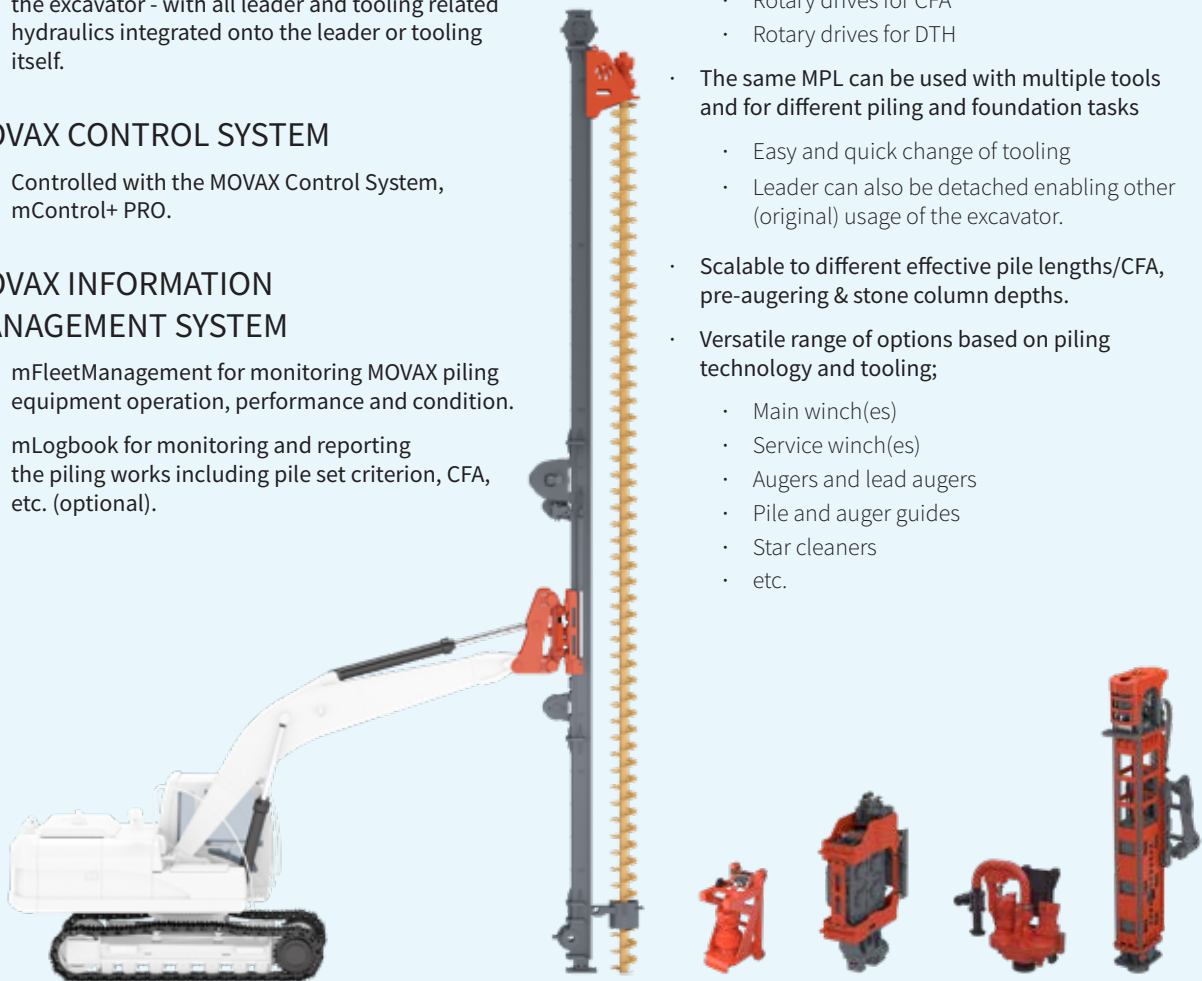

MULTI-TOOL PILING LEADERS

MOVAX MODULAR SYSTEM

MOVAX MPL Multi-tool piling leaders are of a modular design and thus suitable for a wide range of applications and piling technologies. The modularity applies to the tooling which can easily and quickly be changed to allow for the use of the same leader for multiple piling tasks – and to the piling depth: the leader can be shortened for instance for easier transportation and for low head site.



PRE-AUGER



VIBRATORY PILE DRIVER



MOUNTING BRACKET



PILING HAMMER



CFA ROTARY DRIVE



MOVAX MPL Multi-tool piling leaders are available in two basic configurations – MPL-300 and MPL-400 – which are suitable for different size excavators; depending on the excavator, which must always be checked for hydraulic power and stability, the MPL is either stick or boom mounted.

Depending on the piling application and tooling, MPL Multi-tool piling leaders are available with different options.

OPTIONS



Main winch available with different lifting force (*1x or 3x winch line pull*).

MPL available also with optional service winch for lifting piles, augers and reinforcements.

Mounted directly onto excavator, stick or onto main boom (*depending on excavator class*).
Excavator- and mounting-specific adapter included in the delivery.



Available with tool specific accessories; for example *CFA auger star cleaner*

Available with pile or auger guide for accurate positioning and verticality.
Pile clamps either mechanical or hydraulic.



Lead augers and augers are available for different soil conditions and with different diameters.



MULTI-TOOL PILING LEADERS

SELECTION

The MOVAX MPL Multi-tool piling leader (MPL-300, MPL-400) and its associated tooling is selected based on the following:

- Excavator brand and model
- Piling technology & tooling options; multiple tooling options can be used on the same MPL multi tool piling leader
- Pile and augering dimensions (weight, length/depth, diameter, etc.)
- Soil and site conditions
- Transportation conditions & requirements

The MOVAX MPL Multi-tool piling leader is always customised based on the customer specific requirements.

Excavator (carrier)

The excavator class (brand & model) effects the selection of the MOVAX Multi-tool piling leader configuration and the correct model (MPL-300 or MPL-400).

The excavator class also effects the possible mounting options: boom or stick.

note!

The excavator suitability (hydraulic power/stability) to be checked.



Piling technology & tooling options

The same MOVAX MPL Multi-tool piling leader can be used for multiple piling technologies and with different tooling.

Pre-auger rotary drive

MPL-300		Torque
T-5000		50 kNm
MPL-400		Torque
T-5000		50 kNm
T-10000		100 kNm
Options		
Augers & lead augers (300-600 mm)		- heavy duty, conical - rock, cylindrical
Auger guides		



CFA Rotary drive

MPL-300		Torque
RHX-52		50 kNm
MPL-400		Torque
RHX-52		50 kNm
RHP-10		100 kNm
Options		
Augers & lead augers (300-600 mm)		- heavy duty, conical - rock, cylindrical
Auger drives		
Rotary drive		- electrical shifting - flushing head & pipe - pressure measuring device
Concrete flow meter		
mLogbook		



Vibratory pile driver

MPL-300		Centrifugal force
TG-120		718 kN
MPL-400		Centrifugal force
TG-120		718 kN
TG-160		912 kN
Options		
Bottom clamp		pads for different type of piles
Pile guides		



Piling hammers

MPL-300		Impact energy
DH-15		15 kNm
DH-25		25 kNm
MPL-400		Impact energy
DH-15		15 kNm
DH-25		25 kNm
DH-35		35 kNm
DH-45		45 kNm
Options		
Pile caps for different type of piles		
Pile guides		



MULTI-TOOL PILING LEADERS

TECHNICAL DATA

Model		MPL-300	MPL-400
Weight (without adapter & tool)	kg	5000-5250	7000-8000
Height	m	15	15
Forward inclination	°	20	20
Backward inclination	°	20	20
Tilt	°	8	8
Rotation (optional)	°	60	60
Winches			
Main winch	kN	57	120
Crowd winch	kN	57	120
Aux winch	kN	25	57
Crowd system			
Max. pull down force	kN	114	120
Max. extraction force	kN	171	120/360
Transport (w/o excavator)			
Length	mm	8600	8700
Width	mm	1800	2900
Height	mm	2000	2900
Weight (w/o tool)	kg	5300-5550	7000-8000
Excavator class	t	30-50	35-50
Accessories/options			
Mechanical or hydraulic guides			
Star (auger) cleaner			
Pulley system depending on tooling/application			

NOTE!

Weights and dimensions - and other features - are tentative and provided for general information purposes only. The MPL leader will always be customised to meet customer specific requirements.

Excavator suitability (hydraulic capacity/stability) to be checked.

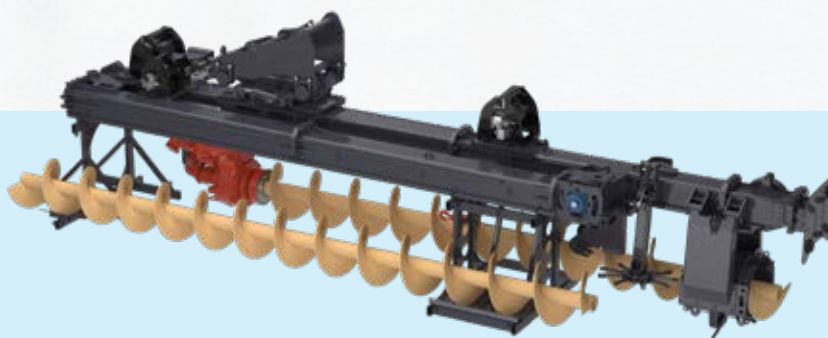

MPL in transit





 **MOVAX**

MULTI-TOOL PILING LEADERS

TECHNICAL DATA

Piling hammers

Model		DH-15	DH-25	DH-35	DH-45
Total weight	kg	2800	3700	4900	5850
Ram weight	kg	1360	2060	3100	4000
Blows per minute	1/min	0-100	0-100	0-100	0-100
Impact energy	kNm	0-15	0-25	0-35	0-45
Drop height	m	0-1,2	0-1,2	0-1,2	0-1,2
Total height	mm	3850	4460	4460	4930
Frame width	mm	500	500	650	650
Transport width	mm	1200	1200	1200	1200
Transport depth	mm	1870	1870 </td <td>1870</td> <td>1870</td>	1870	1870
Oil flow	l/min	80-120	80-120	80-120	80-120
Operating pressure	bar	150	200	250	280
Pressure relief set, max	bar	350	350	350	350
Suitable piles					
Sheet piles		U and Z, max length 12 m			
H-beams		up to HEB500, max length 12 m			
Tubular steel piles		up to Ø 508 mm, 12 m up to Ø 762 mm, 8 m			
Precast concrete		up to 250x250 mm, max length 12 m			



Mounting bracket

The same mounting bracket can be utilized for different tooling mounted on the MPL multi-tool piling leader.



Top cover

The same top cover can be used when mounting the MOVAX DH piling hammer directly onto the excavator.



Lower frame



Pile caps

Pile caps are available for different type of piles – ranging from sheet piles and tubular steel piles to precast concrete piles.



MULTI-TOOL PILING LEADERS

TECHNICAL DATA

Vibratory pile drivers

Model		TG-120	TG-160
Total weight (transport)	kg	2460	2775
Total weight (operating)	kg	2385	2700
Dynamic weight	kg	1810	2100
Dynamic weight (excl. clamp)	kg	1230	1280
Height	mm	2500	2500
Depth	mm	1330	1330
Width	mm	460/410*	460/410*
Eccentric moment	kgm	12,6	16
Frequency	1/s	2300	2300
Line pull, max	kN	200	200
Amplitude	mm	14,5/20**	15,2 /25**
Centrifugal force	kN	718	912
Oil flow	l/min	240	300
Operating pressure, max	bar	350	350
Excavator class	ton	35-50	42-50
Suitable piles			
Sheet piles		U and Z, max length 12 m	
H-beams		up to HEB500, max length 12 m	
Tubular steel piles		up to Ø 508 mm, 12 m	
		up to Ø 762 mm, 8 m	

NOTE!

* total/along piling line

** with/without bottom clamp





MULTI-TOOL PILING LEADERS

TECHNICAL DATA

Pre-auger rotary drive

Model		PD-50	PD-100
Total weight	kg	600	1000
Torque, max	kNm	50	100
Drilling speed	rpm	0-40	0-40
Connecting pin, hexagonal	mm	70	130
Oil flow	l/mm	240	240
Maximum pressure	bar	350	350
Pre-augering			
Depth	m	12	12
Hole diameter	mm	300-600	300-800
Lead augers		size, mm	300-600
		type	heavy duty, conical rock, cylindrical
Augers		length, m	3 or 6
		size, mm	300-600
		type	heavy duty, conical rock, cylindrical
Connection			
Auger guide		Each auger diameter requires auger guide of corresponding size.	



Lead augers

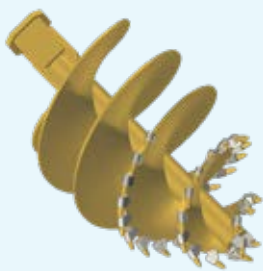

Heavy duty/conical

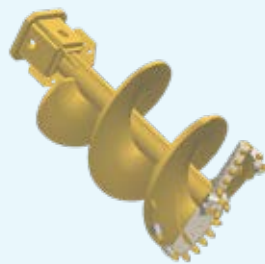

Rock/cylindrical

Augers

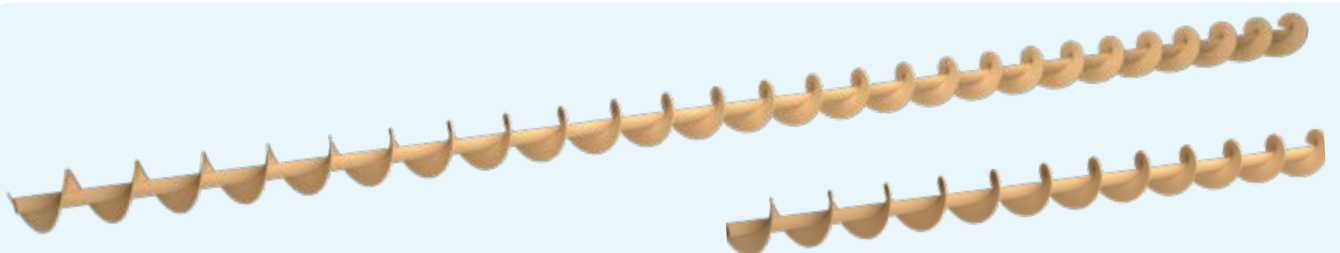



MULTI-TOOL PILING LEADERS

TECHNICAL DATA

CFA rotary drive

Model		RHP-10	RH52X
Total weight	kg	1800	1200
Torque, max	kNm	100	52
Drilling speed	rpm	0-50	0-50
Connection		bolt-on flange	
Oil flow	l/mm	250	250
Maximum pressure	bar	320	320
CFA			
Depth	m	12	12
Hole diameter	mm	300-800	300-600
Rotary drive		- electrical shifting - flushing head & pipe - pressure measuring device	
Concrete flow meter			
mLogbook			
Lead augers	size, mm	300-600	
	type	heavy duty, conical rock, cylindrical	
Augers	length, m	3 or 6	
	size, mm	300-600	
	type	heavy duty, conical rock, cylindrical	
Auger guide		Each auger diameter requires auger guide of corresponding size.	



The Continuous Flight Auger (CFA) rotary drive is supplied with the following options:

Options

1. Pressure measuring device
2. Flushing pipe
3. Concrete flow meter
4. Flushing head
5. Rotary head
6. Adaption kit for concrete pipe





MULTI-TOOL PILING LEADERS

TECHNICAL DATA

Rotary drives for DTH

Model		GEONEX GR15	GEONEX GR50
Max. casing diameter	mm	323,9	610
Weight	kg	200	650
Length	mm	363	520
Width	mm	400	580
Height	mm	370	615
Thread connection		Api Reg 2 3/8" F, Api Reg 3 1/2" F, Api Reg 4 1/2" F	Api Reg 3 1/2" F, Api Reg 4 1/2" F, Api Reg 6 5/8" F, Hex heads
Max. oil flow	l/min	270	300
Max. oil pressure	bar	250	250
Max. torque, slow gear	kNm	min 7,5 / max 15	min 14 / max 55
Max. torque, fast gear	kNm	min 5 / max 10	min 9,3 / max 37,5
Max. rotation speed, slow gear	rpm	min 60 / max 30	min 57 / max 14
Max. rotation speed, fast gear	rpm	min 90 / max 45	min 85 / max 21

Suitable DTHs (Down-the-Hole-Hammers)

Model		DTH size	DTH size
139,7	mm	4"	4"
168,3	mm	5"	5"
219,1	mm	6"/7"	6"/7"
273	mm	8"	8"
323,9	mm	10"	10"
406,4	mm	NA	12"
508	mm	NA	15"
610	mm	NA	18"

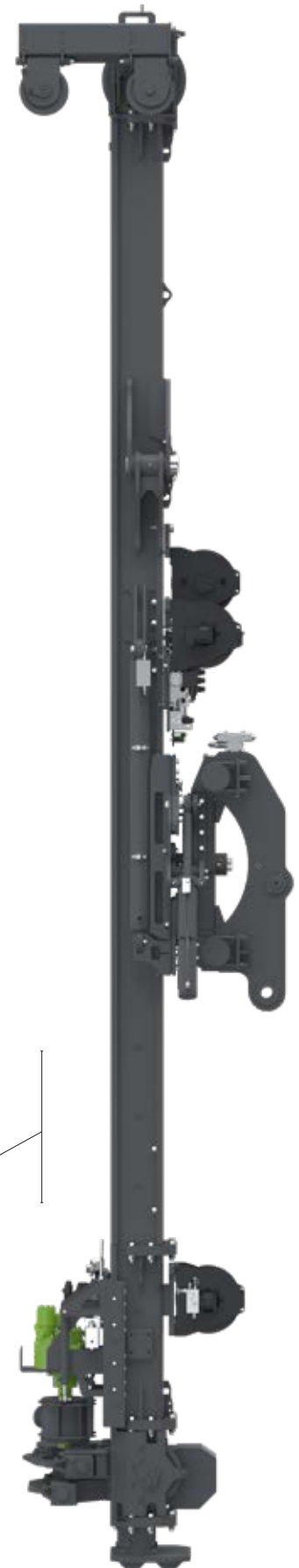



MULTI-TOOL PILING LEADERS

MPL-300 for pre-augering

Model		MPL-300
Main dimensions		
Weight (w/o adapter & tool)	kg	5300-5600
Height	m	abt. 15
Forward inclination	°	5
Backward inclination	°	10
Tilt	°	±8
Winches		
Main winch	kN	57
Crowd winch	kN	25
Crowd system		
Max. pull down force	kN	57
Max. extraction force	kN	57
Effective depth	m	12
Hole diameter	mm	300-600
Excavator		
Brand & Model**		TBD
Engine power	kW	
Operating weight	t	>30
Mounting**		>30 t stick or boom
Accessories		
Auger guide, mechanical or hydraulic***	mm	600

* w/o adapter and tool

** stability and mounting to be checked

*** each diameter requires its own guide with matching size

Rotary drive		Hydra T-5000
Main design data		
Total weight	kg	600
Torque, max.	kNm	50
Drilling speed	rpm	0-40
Connecting pin, hexagonal	mm	70
Oil flow	l/min	240
Maximum pressure	bar	350
Drilling parameters		
Depth	m	12 m
Hole diameter, max.	mm	300-600
Accessories		
Mounting bracket		

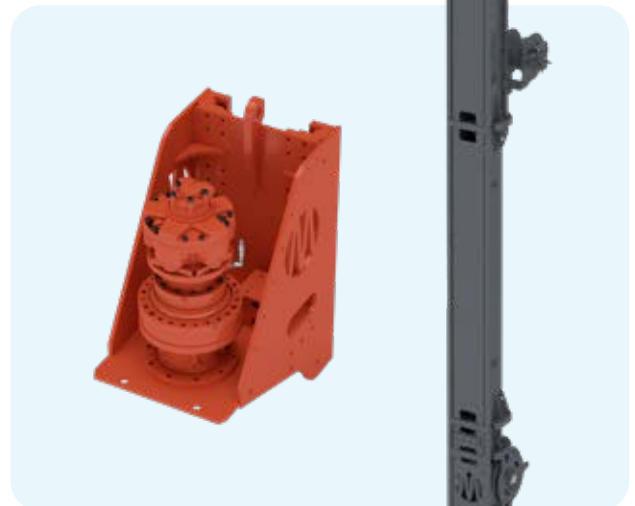

MULTI-TOOL PILING LEADERS

MPL-300 for CFA

Model		MPL-300
Main dimensions		
Weight (w/o adapter & tool)	kg	5300-5600
Height	m	abt. 15
Forward inclination	°	5
Backward inclination	°	10
Tilt	°	±8
Winches		
Main winch	kN	57
Crowd winch	kN	57
Auxiliary winch	kN	25
Crowd system		
Max. pull down force	kN	114
Max. extraction force	kN	171
Effective depth	m	12
Hole diameter	mm	300-600
Excavator		
Brand & Model**		TBD
Engine power	kW	
Operating weight	t	>30
Mounting**		>35 t stick >30 t boom
Accessories		
Auger cleaner		"star"-type
Auger guide, mechanical or hydraulic***	mm	300-600

* w/o adapter and tool

** stability and mounting to be checked

*** each diameter requires its own guide with matching size

Rotary drive		Eurodrill RH52X
Main design data		
Total weight	kg	600
Torque, max.	kNm	50
Drilling speed	rpm	0-40
Connection		bolt-on flange
Oil flow	l/min	240
Maximum pressure	bar	350
Drilling parameters		
Depth	m	12
Hole diameter, max.	mm	300-600
Accessories		
Electrical shifting		
Concrete flow meter		
Mounting bracket		



MULTI-TOOL PILING LEADERS

MPL-300 for vibro driving

Model	MPL-300	
Main dimensions		
Weight (w/o adapter & tool)	kg	5300-5600
Height	m	abt. 15
Forward inclination	°	5
Backward inclination	°	10
Tilt	°	±8
Rotation	°	±60
Winches		
Main winch	kN	57
Crowd winch	kN	57
Auxiliary winch	kN	25
Crowd system		
Max. pull down force	kN	114
Max. extraction force	kN	172
Effective pile length	m	12
Excavator		
Brand & Model**		TBD
Engine power	kW	150
Operating weight	t	>30
Mounting		>35 t stick >30 t boom
Accessories		
Pile guide, mechanical or hydraulic***	mm	TBD

* w/o adapter and tool

** stability and mounting to be checked

*** each diameter requires its own guide with matching size

Model	TG-120	
Main design data		
Total weight	kg	2385
Eccentric moment	kgm	12,6
Frequency	1/s	2300
Amplitude	mm	14,5/20*
Centrifugal force	kN	718
Oil flow	l/min	240
Operating pressure, max	bar	350
Accessories		
Bottom clamp		
Suitable piles		
Sheet piles		
Tubular steel piles		

*with/without bottom clamp

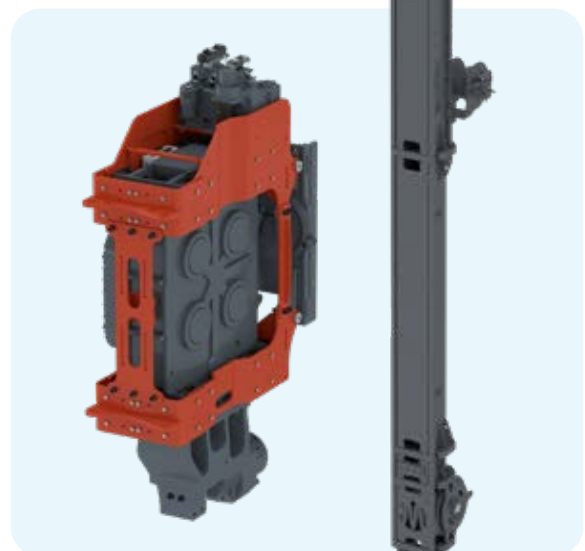

MULTI-TOOL PILING LEADERS

MPL-300 for impact driving

Model		MPL-300
Main dimensions		
Weight*	kg	5300-5600
Height	m	abt. 15
Forward inclination	°	5
Backward inclination	°	10
Tilt	°	±8
Winches		
Main winch	kN	57
Crowd winch	kN	25
Auxiliary winch	kN	25
Crowd system		
Max. pull down force	kN	25
Max. extraction force	kN	57
Effective pile length	m	12
Excavator		
Brand & Model**		TBD
Engine power	kW	
Operating weight	t	>30
Mounting		>30 t boom
Accessories		
Pile guide, mechanical or hydraulic***	mm	600

* w/o adapter and tool

** stability and mounting to be checked

*** each diameter requires its own guide with matching size

Piling hammer		DH-25
Main design data		
Total weight	kg	4400
Ram weight	kg	2060
Blows per minute	1/min	0-100
Drop height	m	0-1,2
Impact energy	kNm	0-25
Oil flow	l/min	200
Operating pressure, max	bar	350
Suitable piles		
Sheet piles		
Tubular steel piles		
Precast concrete piles		

*with/without bottom clamp





INTRODUCTION

COLUMN STABILISATION LEADERS

MOVAX excavator-mounted **MSL column stabilisation leaders** provides a versatile solution for soil improvement in a wide range of site and soil conditions when utilising dry binder material.

MOVAX column stabilisation leader and its tooling are designed to work on a standard excavator with normal auxiliary hydraulics and are controlled with the MOVAX Control System.

MOVAX MSL column stabilisation leaders are based on a modular concept and always customised to meet customer-specific requirements.



COLUMN STABILISATION LEADERS

FEATURES

EXCAVATOR-MOUNTED

- Excavator mounted, heavy duty column stabilisation leader.
- Available for a wide range of excavators starting from 30 tons and larger.
- Boom or stick mounted based on excavator stability. Delivered with excavator- and mounting specific adapter.
- Designed to work on any and all wheeled and crawler-type excavators and rail roaders by utilising and commanding the standard auxiliary hydraulics and/or by connecting to the electronic control of the excavator - with all leader and tooling related hydraulics integrated onto the leader or tooling itself.

CUSTOM DESIGN BASED ON STANDARDIZED MODULES

- Maximum depth 20-25 meters depending on excavator size; due to the modular design the leader can be shortened to 12 or 16 meter effective depth.
- Column diameters between Ø500–800 mm due to interchangeable mixer tip.
- Mixer tip vertical movement is achieved with two hydraulic winches.
- Binder feed at the top of the mixing rod to which a rotating joint for the binder hose is integrated.
- Roller mechanism on the rotary drive to apply torque and simultaneously allow feedthrough of the mixing tube.
- Integrated rotary drive and telescopic bottom foot at the end of the leader.
- Additional support for binder feed hoses and electric cables along the leader.

MOVAX CONTROL SYSTEM

Controlled with the MOVAX Control System, mControl+ PRO.

MOVAX INFORMATION MANAGEMENT SYSTEM

mLogbook for monitoring and reporting the column stabilisation work.

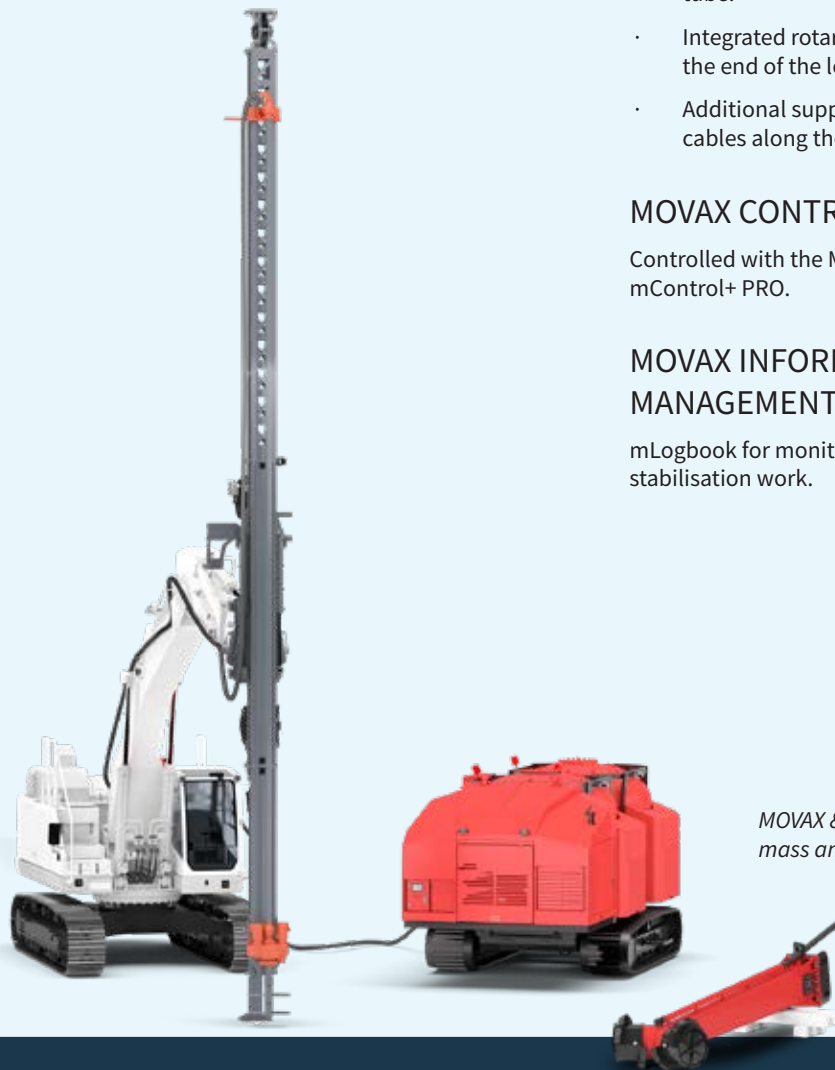

MOVAX & ALLU co-operate to deliver a complete mass and column stabilisation solution.

SOIL IMPROVEMENT



COLUMN STABILISATION LEADERS

TECHNICAL DATA

Model		MSL-300
Column depth	m	12-25
Column diameter	mm	500-800
Weight (w/o adapter)	kg	6500
Height	m	23-28
Tilt angle	°	+/- 8
Winches		
Main winch	kN	57
Crowd winch	kN	25
Crowd system		
Max. pull down force	kN	57
Max. extraction force	kN	57
Speed	m/min	0-30

Rotary drive		
Torque	kNm	20
Rotational speed	rpm	180-200
Features/instrumentation		
<ul style="list-style-type: none"> · rotation speed · rotation torque · column depth/ascent rate · driving angle 		

Mixer/mixer tip		
Mixer tip levels	pcs	4
Diameter	mm	500-800, nominal
Binder feed	kg/s	3,0
Compressed air, pressure	bar	10
Compressed air, flow rate	m ³ /min	6,5
Ascent rate	mm/r	20
Rotational velocity	rpm	180-200
Injection pipe		
length	m	21,3-26,3
inner diameter	mm	34
Support pipe		
length	m	21,3-26,3
size / wall thickness	mm	100 x 100 mm square/8 mm

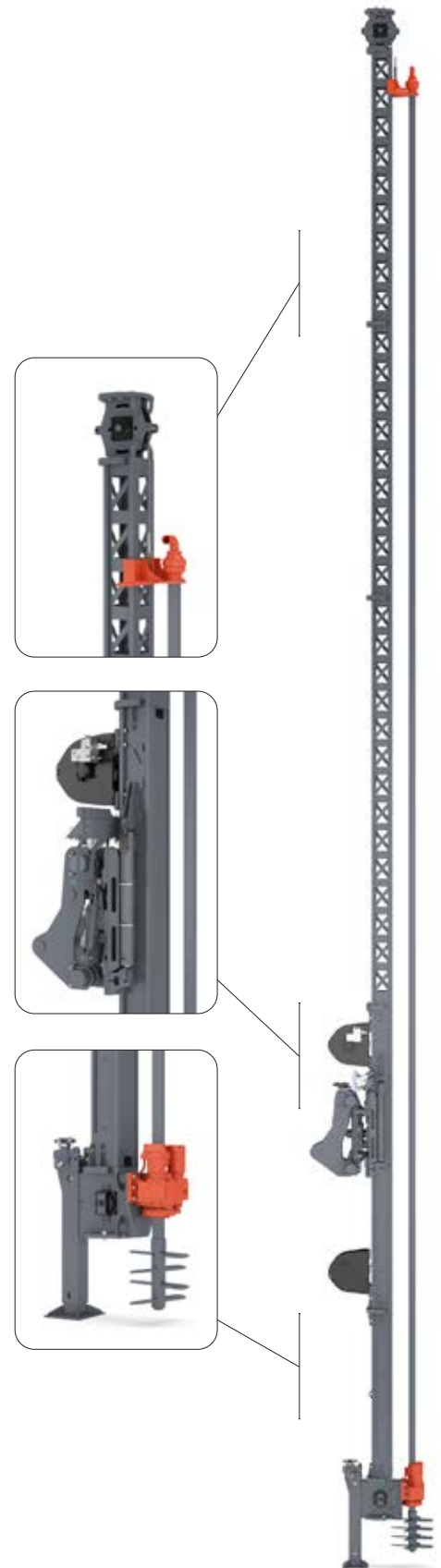

Detailed technical data to be provided on case by case basis.
Column depth and other technical data dependent on excavator size.



COLUMN STABILISATION LEADERS

MONITORING & REPORTING

The Column stabilisation process is controlled and the work is monitored using the MOVAX mControl+ PRO control system. The mControl+ PRO is designed to communicate with external systems such as ALLU's DAC control system and different 3D systems (the connectivity will be developed on a case-by-case basis).

The control, monitoring and reporting system consists of the following systems which communicate with each other over the CAN-bus:

- MOVAX mControl+ control system
- MOVAX mLogbook reporting system
- ALLU DAC control system or other feed system
- Third party 3D system connectivity

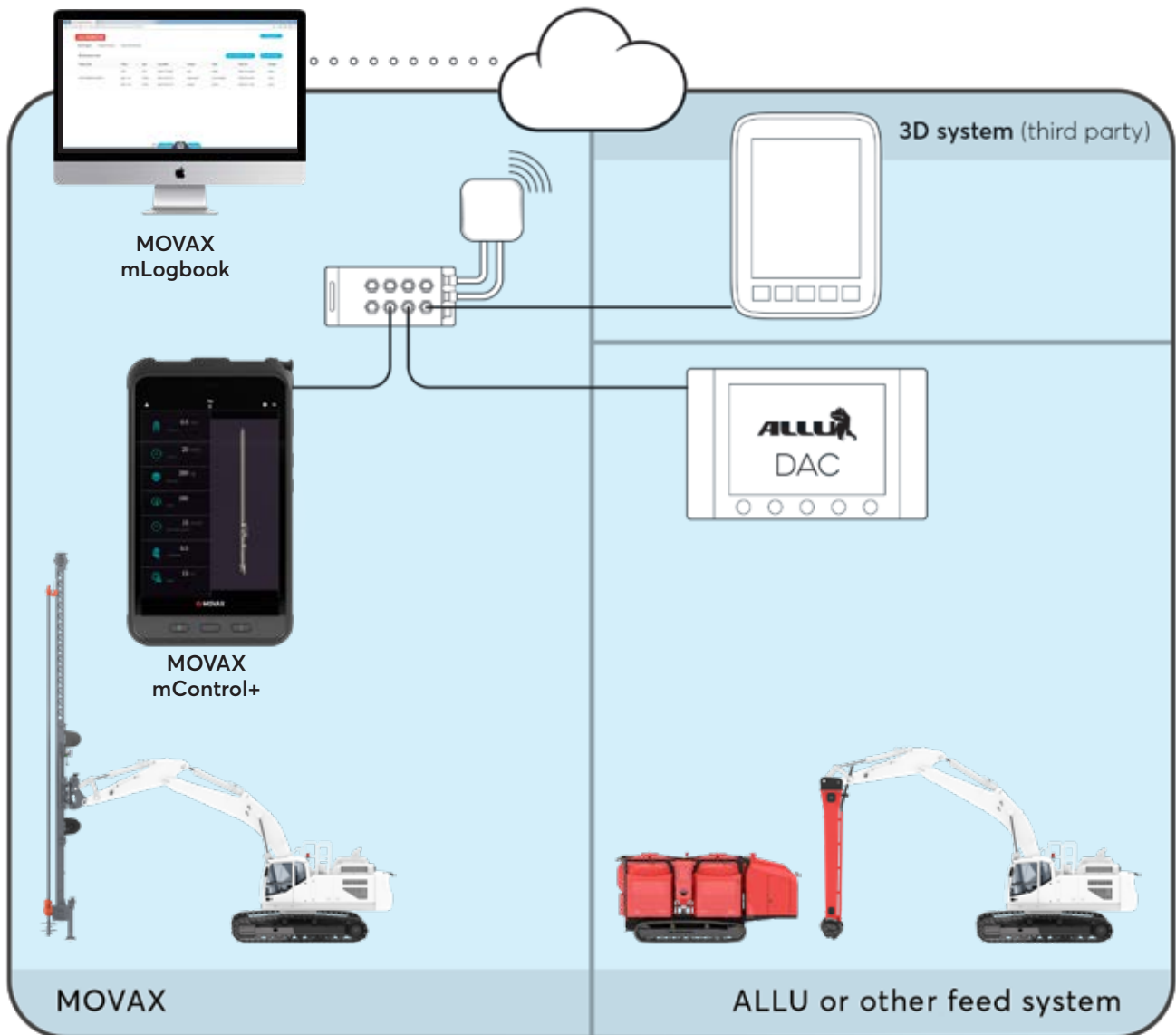



PLANNING

The stabilisation drawings and plans are accessed through the 3rd party 3D system. From the display the operator can see the planned location of the mass stabilisation fields or the stabilisation columns.

MONITORING

The work flow is monitored utilizing MOVAX mControl+ and the 3rd Party 3D-system. The location and positioning data is monitored utilizing the 3rd Party 3D system display. The mControl+ -display is utilized to monitor all other stabilisation parameters such as;

- column stabilisation; for example binder quantity per column, ascent rate and rotational speed
- mass stabilisation; for example binder quantity, feed and mixing times

The operator can view the result of the stabilisation work on the displays of the MOVAX mControl+ and the 3rd Party 3D-system. The realised positioning data is shown in the 3rd Party 3D system whereas all other reported parameters can be found in the MOVAX mControl+ system.



REPORTING

The mass and column stabilisation work is reported utilizing the 3rd Party 3D-system as well as MOVAX mLogbook reporting system.

The MOVAX mControl+ system sends the data to a cloud-based server (mCLOUD) where all the information is stored. The user can access the information and ready made reports through a password protected web-based interface.

In addition to ready made reports the MOVAX mLogbook-reporting system also includes efficient tools for printing (pdf-format) and to transfer the data to for instance Microsoft Excel.



mControl+ is always installed so that the original functionality of the excavator is maintained – ie. no changes are made to the excavator and it can be used for all its other intended or original usage.

INTRODUCTION

MOVAX CONTROL SYSTEM

The MOVAX Control System, **mControl+**, links the carrier (excavator, rail roader or equal) with the MOVAX piling equipment - and is a vital, inseparable part of MOVAX way-of-piling resulting in higher productivity, a high-quality end-result and the safety of the piling process – and in a maximum availability of the MOVAX piling equipment.

mControl+ is controlling the standard auxiliary pilot circuit of the excavator which in turn controls the excavator's auxiliary hydraulics - thus controlling all the functions of the MOVAX piling equipment. mControl+ utilizes inclination and pressure sensors to monitor and control the operation of the MOVAX piling equipment and the pile driving process.

The same mControl+ control system is used to operate all MOVAX piling equipment.

Productivity & efficiency

mControl+ enables the operator to efficiently and accurately control the MOVAX piling equipment for a higher productivity. mControl+ is available in two versions:

- mControl+ PRO with automatic control
- mControl+ LITE

mControl+ automatically optimises the flow to the different functions of both the MOVAX piling equipment and the excavator as required during the pile driving process. This also results in the highest possible fuel efficiency and economy.

Precision & accuracy

Smooth movements, precision and accuracy in the pile installation is achieved with the proportional control of mControl+.

mControl+ not only controls the operation of the MOVAX pile driving equipment - and thus ensures the precision and accuracy of the pile driving process – but it also displays vital information about the pile driving process which supports the operator to achieve not only efficiency but also precision and accuracy.

Safety

mControl+ is further utilized to set and monitor operational and safety related parameters related to the MOVAX piling equipment ensuring the utmost safety in the pile driving process.



MOVAX Multi-tool piling leaders require mControl+ PRO



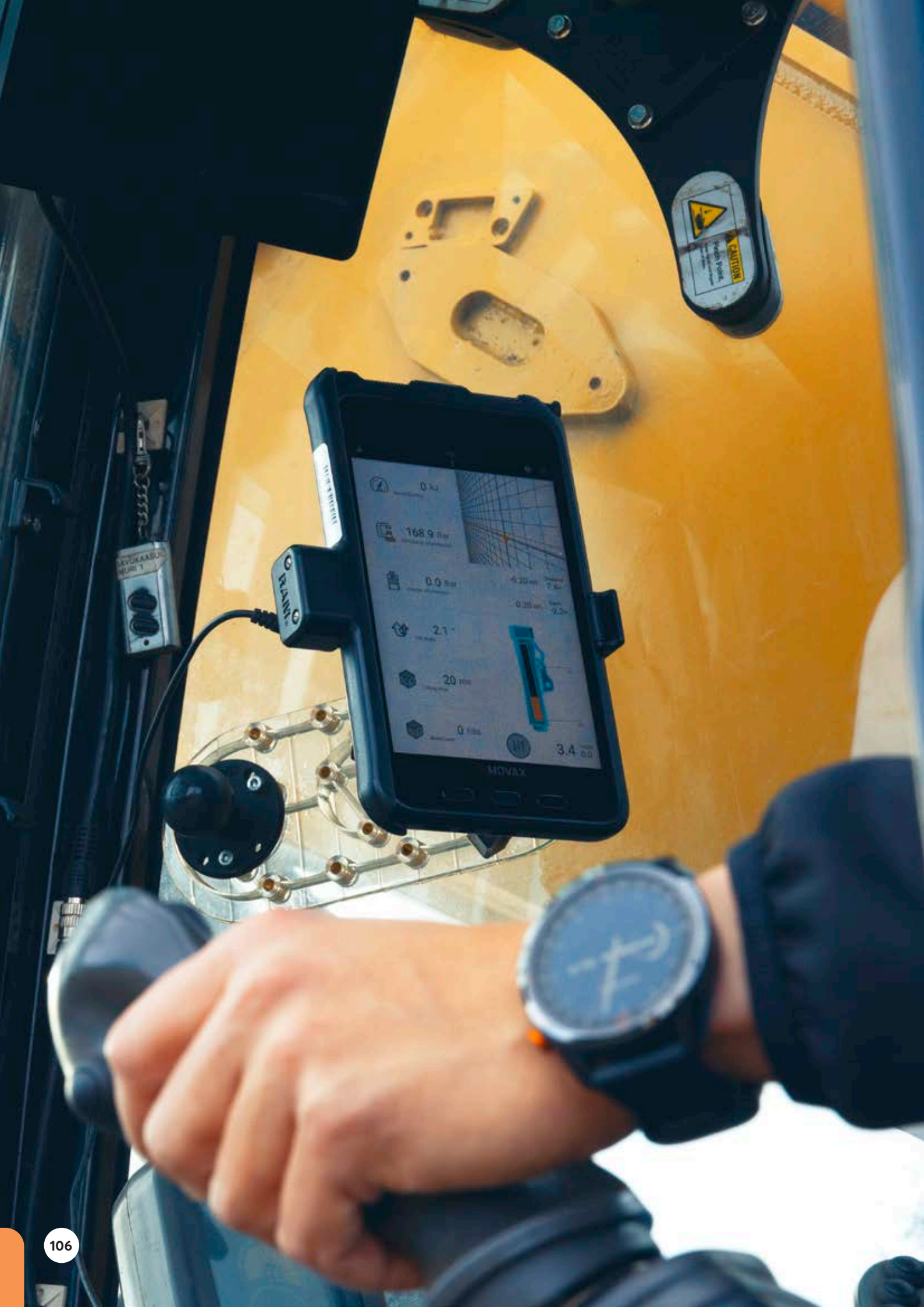

FEATURES

EXCAVATOR MOUNTED

Commanding the standard auxiliary hydraulic circuit of the excavator. The excavator's auxiliary pilot circuit is controlled optionally:

- Hydraulically, with a hydraulic valve block
- Electronically, with a PWM-module
- Through a CAN interface

STATE OF THE ART, ADVANCED CONTROL SYSTEM

Based on proportional control for speed, precision and accuracy;

- **mControl+ PRO**, Automatic control system with tip-control
- **mControl+ LITE**, Basic control system

note! MOVAX MPL Multi-tool piling leaders require mControl+PRO

EASY AND EFFICIENT DIAGNOSTICS

Available directly on the mControl+ display.

ERGONOMIC AND INFORMATIVE USER INTERFACE

- Provides valuable information related to operation, performance, safety and availability
- Color display
- Easy-to-read graphical symbols
- User-friendly menus for calibration and performance optimization
- All functions are effortlessly controlled using switches and thumb wheels on the control grips

SAFETY

Integrated safety features.

CONNECTIVITY TO MOVAX INFORMATION MANAGEMENT SYSTEM

- mFleetManagement
- mLogbook

note! mLogbook requires mControl+PRO

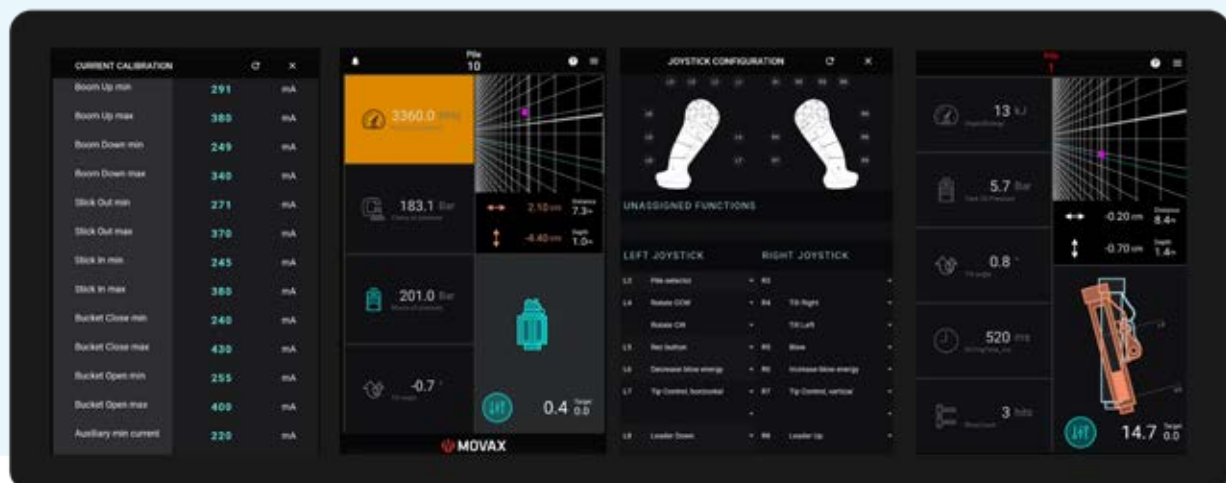

INTRODUCTION

mControl+ PRO

mControl+ PRO is a state-of-the-art automatic control system based on advanced ‘tip’-control computing technology and angle sensors mounted onto the excavator’s boom and stick which utilises either proportional pilot valves, a PWM controller or a CAN pilot circuit/interface for the control of the excavator’s auxiliary hydraulics. mControl+ PRO is installed onto the excavator without making any changes to the original functionality of the excavator whatsoever.

The *automatic control* of the mControl+ PRO effectively assists the operator in achieving a faster and more efficient, high quality piling installation. The mControl+ PRO also provides valuable information which further assists the operator in achieving a higher production rate and quality. The information also ensures the highest possible availability by providing information protecting the MOVAX piling equipment.

mControl+ PRO is utilised to control all MOVAX piling equipment - including SG side grip pile drivers, DH piling hammers, TAD/KB piling drills and MPM manipulators – and MPL multi-tool piling leaders and MSL column stabilisation leaders.

mControl+ PRO

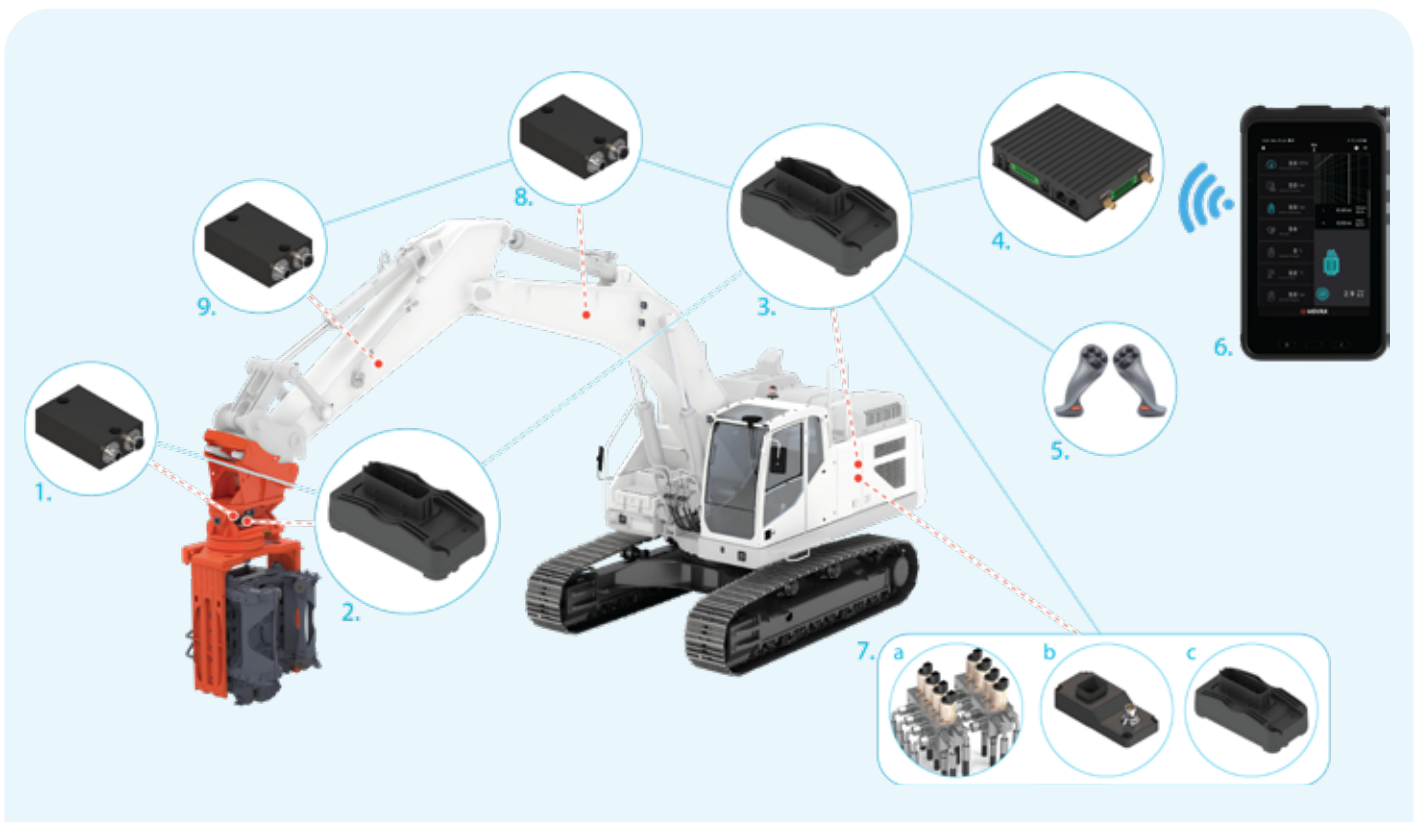

- 1. MOVAX Angle sensor (MxS)
- 2. MOVAX Module (MxM)
- 3. Excavator module (ExM)
- 4. MIMS Module
- 5. Control grips

- 6. mControl+ Display
- 7. Pilot circuit control
 - a) Hydraulic valve block
 - b) PWM Control
 - c) CAN Interface

- 8. Boom angle sensor
In case of two-piece boom one additional sensor is required
- 9. Stick angle sensor

mControl+ PRO

FEATURES

Automatic Control System

- Controls all the main functions of the MOVAX piling equipment and MOVAX customised solutions
- Automatic control for MOVAX SG side grip pile drivers and DH piling hammers based on state-of-the-art tip control technology

Informative Control & Monitoring System

- Comprehensive information about the pile driving process - from verticality to refusal
- Detailed information for monitoring of equipment operation, performance and condition

Display

- Android tablet, 8"
- Color display
- Ergonomic user interface for set-up/input data, monitoring and operation



Control grips

- Ergonomic control grips with 2- or 3-rollers and buttons which allow complete operation with a single grip.
- Extra buttons and rollers are provided for accommodating functions from the excavator's original handles, as necessary.



Control modules

- Excavator cab-mounted EXM controls the excavator's auxiliary hydraulics with either proportional valves, a PWM controller or a CAN bus control circuit.
- Factory installed MXM delivered with the MOVAX equipment, controls the hydraulic valves on the MOVAX piling equipment.

Angle sensors

- Highly accurate angle and distance information designed for extreme vibration conditions.
- nextGen 360° angle sensors with gyroscopes for maximal accuracy.
- Additional sensor(s) for excavators with a two-piece boom

mControl+ PRO

FEATURES

Automatic control

mControl+ PRO is equipped with the advanced, automatic, tip-control feature assisting the operator in achieving a faster and more precise piling process and ultimately resulting in higher production rates and increased quality of installation.

MOVAX mControl+ automatic tip-control utilizes the power of computing, pre-programming and sensors in such a manner that a single action by the operator affects multiple movements at the same time. The auto-functionality is based on angle sensors mounted onto the carrier's boom and stick, and the MOVAX piling equipment* and the proportional pilot control of the excavator's auxiliary hydraulics.

The automatic control makes the MOVAX piling equipment travel in a straight line by taking over demanding parts of the excavator's boom control.

The mControl+ PRO tip-control feature, which makes the MOVAX side grip pile driver or MOVAX piling hammer travel vertically in a straight line, can principally be divided into two parts: Vertical Tip Control [Y-AXIS] and Horizontal Tip Control [X-AXIS].

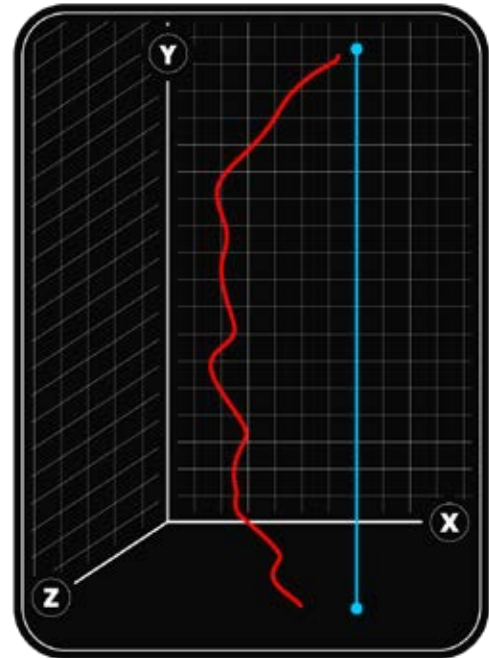

mControl+ PRO

FEATURES

The operator can pilot the boom assembly of the excavator in both directions, up and down (Y-axis) and forwards and backwards (X-axis), with single control grip roller commands – with a horizontally constant distance position, and the with the MOVAX side grip pile driver or MOVAX piling hammer parallel to the pile at all times. The speed of the action can be adjusted fly-by with the proportional roller when the movement occurs. Highly accurate calibrations can be done in the mControl+Pro application, based on operator preference.

The tip control-feature (**Y-axis**) is used when driving or extracting piles with the MOVAX Side grip pile driver, or to change the position of the MOVAX side grip pile driver along the pile for the purpose of re-gripping the pile.

The tip control-feature (**X-axis**) is used when accurate and steady horizontal movement is required – a particularly good example is sheet pile pitching: Guiding the pile into the lock insert is faster when the MOVAX side grip pile driver and the pile are in zero level and the MOVAX side grip pile driver motion only happens in the X-axis of the coordinate system.

Vertical movement with a stationary excavator.



Horizontal movement with a stationary excavator.

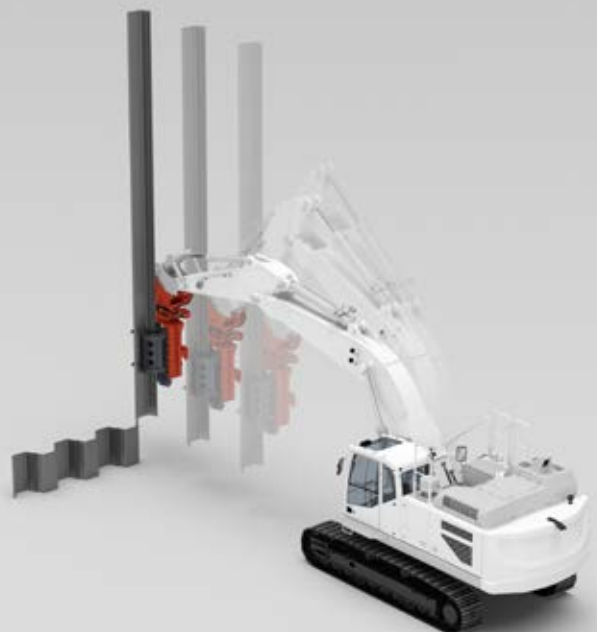

mControl+ PRO

FEATURES

Information

mControl+ PRO provides comprehensive and essential information about the operation of the MOVAX piling equipment and the piling process itself, allowing the operator to monitor and optimize the operation for the best possible overall performance.

The mControl+ PRO provides the following key information (MOVAX SG side grip pile driver):

- **Angle.** Providing information about the verticality.
- **Frequency,** to help the operator keep the performance on the optimum level
- **Oil pressures** with warnings, to ensure the correct operation of the machine
- **Clamp pressure,** providing extra safety to handling and driving process
- **Gear oil temperature** with warnings, to monitor bearing temperatures and maintain the bearing lifetime
- **Eccentric position,** provides information of the current eccentric moment on VA-models
- **Position,** horizontal and vertical distances from the zero point, to increase the operators ability to perform
- **Target angle,** for non-vertical driving
- **Refusal.** Displays a clear and visible warning when the refusal is reached during the pile driving process and ultimately stops the operation, thus protecting the MOVAX piling equipment.
- **Pile ID-number,** when using mLogbook.



The information displayed is dependent on the MOVAX piling equipment in question.





0.0 RPM
0.0 bar
25.9 bar
4.1 °C
31 h
4.0 °C
9.0 bar
-0.5 bar

MDVAX

VERSO 12

0.00
0.00

0.00
24.45

N/A
N/A
N/A

▶

INTRODUCTION

mControl+ LITE

mControl+ LITE is a state-of-the-art control system which utilises either proportional pilot valves, a PWM controller or a CAN pilot circuit/interface for the control of the excavator's auxiliary hydraulics. mControl+ LITE is installed onto the excavator without making any changes to the original functionality of the excavator whatsoever.

mControl+ LITE is utilised to control all MOVAX piling equipment, including SG side grip pile drivers, DH piling hammers, TAD/KB piling drills and MPM manipulators.

mControl+ LITE provides basic information about the operation thus assisting the operator in the piling process.

mControl+ PRO

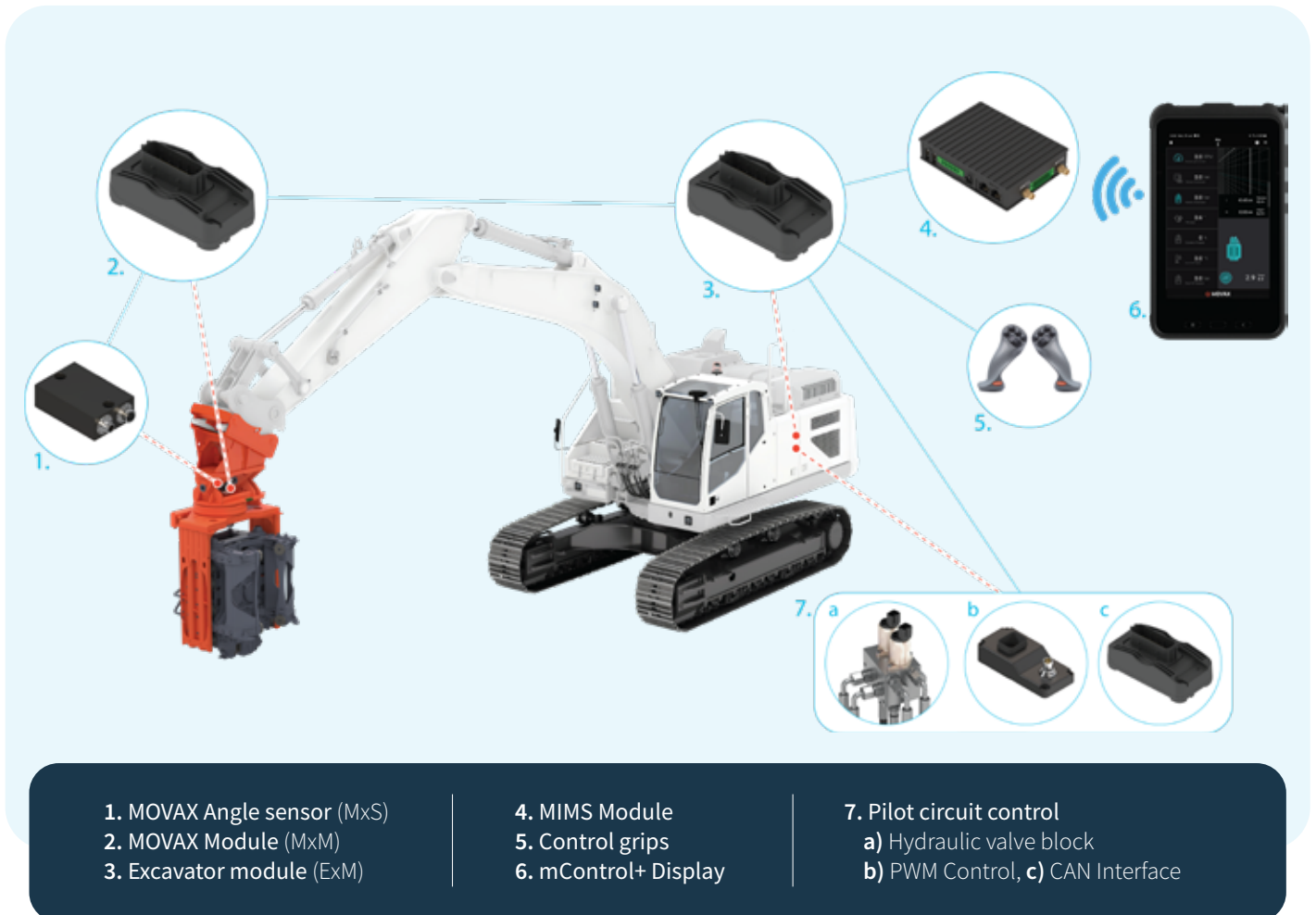

mControl+ LITE

FEATURES

Basic Control System

- Controls all the main functions of the MOVAX piling equipment.

mControl+ LITE can be upgraded to mControl+ PRO with separate upgrade kit.

Informative Control & Monitoring System

- Basic information about the pile driving process and for monitoring of equipment operation and performance.

Display

- Android tablet, 8"
- Color display
- Ergonomic user interface for set-up/input data, monitoring and operation

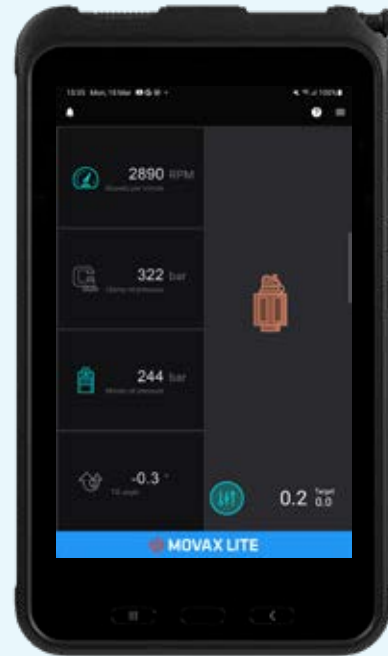

Control grips

- Ergonomic control grips with 2- or 3-rollers and buttons which allow complete operation with a single grip.
- Extra buttons and rollers are provided for accommodating functions from the excavator's original handles, as necessary.



Control modules

- Excavator cab-mounted EXM controls the excavator's auxiliary hydraulics with either proportional valves, a PWM controller or a CAN bus control circuit.
- Factory installed MXM delivered with the MOVAX equipment, controls the hydraulic valves on the MOVAX piling equipment.



INTRODUCTION

INFORMATION MANAGEMENT

MOVAX Information Management Systems (MIMS) provide essential information about the pile driving process – in order to improve the quality of the piling works and to save both time and costs in reporting - and about the MOVAX piling equipment itself – with the aim to maximize the availability.

Data collection, -transfer and -storage

The MIMS hardware (HW), which is a part of the mControl+ MOVAX Control System and installed onto the excavator is utilised for automatic data collection and data transfer. The HW includes a fully integrated 4G/ GPS-system providing the remote connection, and global positioning data. The information is sent to and stored in the MOVAX mCLOUD data storage. The information stored in the mCLOUD data storage is accessed through a web-based user interface. The information can also be accessed through the mFleetCare app.

MOVAX Information Management System is compatible with third-party global positioning systems such as Novatron/MOBA, Trimble and Leica. When connected to a third party global positioning system it is possible to obtain also the exact location of the pile to be driven.

Data suites



mFleet Management

provides essential information about the operation, performance and condition of the MOVAX piling equipment. mFleetManagement is designed to assist in troubleshooting, diagnostics and analysis - and for fast and efficient customer technical support.

mLogbook

is a documentation and reporting tool which provides essential data related to the piling process and the piling or foundation project.





mFleetManagement

FEATURES

The mFleetManagement-data suite provides basic operational, real-time information about the MOVAX piling equipment as well as the general global positioning (GPS) data of the MOVAX piling equipment and the excavator it is connected to. The information can be accessed remotely for adjustment and calibration – and for instance to provide operational guidance and support – as well as for trouble-shooting and quick problem-solving.

mFleetManagement also provides information for the prediction of maintenance requirements thus enabling preventive maintenance with the intent to maximize the availability of the MOVAX piling equipment.

The information can furthermore be utilised for instance for invoicing purposes, etc.

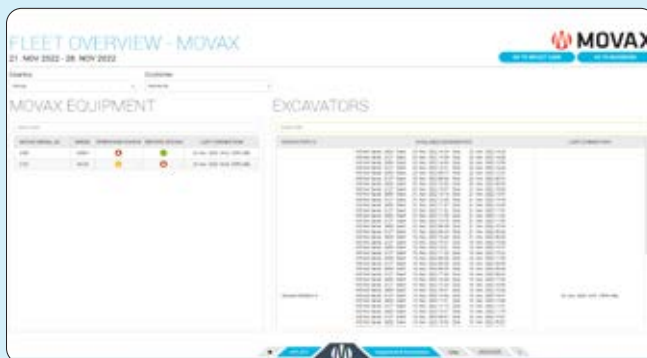

The **'Fleet Overview'** presents an overview of all the MOVAX piling equipment including all the excavators the MOVAX piling equipment is connected to. The 'Fleet overview' also provides a quick overview of the operating and service status of the entire fleet.

The MOVAX piling equipment to be monitored or analysed in more detail is selected from the 'Fleet Overview'.

The main **'Unit Overview'** provides the general information about the specific MOVAX piling equipment in question, its general geographical location, overall utilization hours, operating and service status.

More detailed information is obtained by moving from the 'unit overview' to the ready-prepared reports.

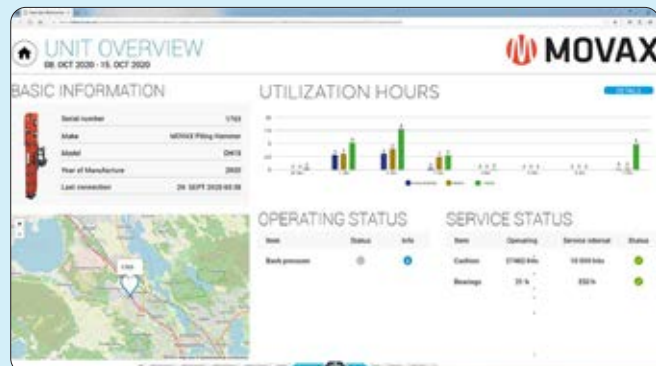

Reports

The operational information is presented in an illustrative, easy-to-view and -browse format. The point-in-time or time interval to be reviewed or analysed can be selected flexibly. The information presented is providing a fast and flexibly overview of the operation, how the unit has been operated – especially in regards to the limits of some of the key operational parameters.



SG rpm/frequency



SG utilization

The ready-made reports include the following:

MOVAX SG Side grip pile drivers	MOVAX DH Piling hammers	MOVAX PA Pre-augers	MOVAX KB/TAD Piling drills	MOVAX MPL Multi-tool piling leaders
Utilization hours	Utilization hours	Utilization hours	Utilization hours	Utilization hours
RPM/Frequency	Back pressure	Working pressure	Working pressure	Working pressure
Working pressure	Refusal*	Back pressure	Back pressure	Back pressure
Back pressure	Service checks	Drain pressure	Drain pressure	Service checks
Drain pressure		Service checks	Service checks	
Clamp pressure				
Refusal*				
Service checks				

*requires mControl+ PRO

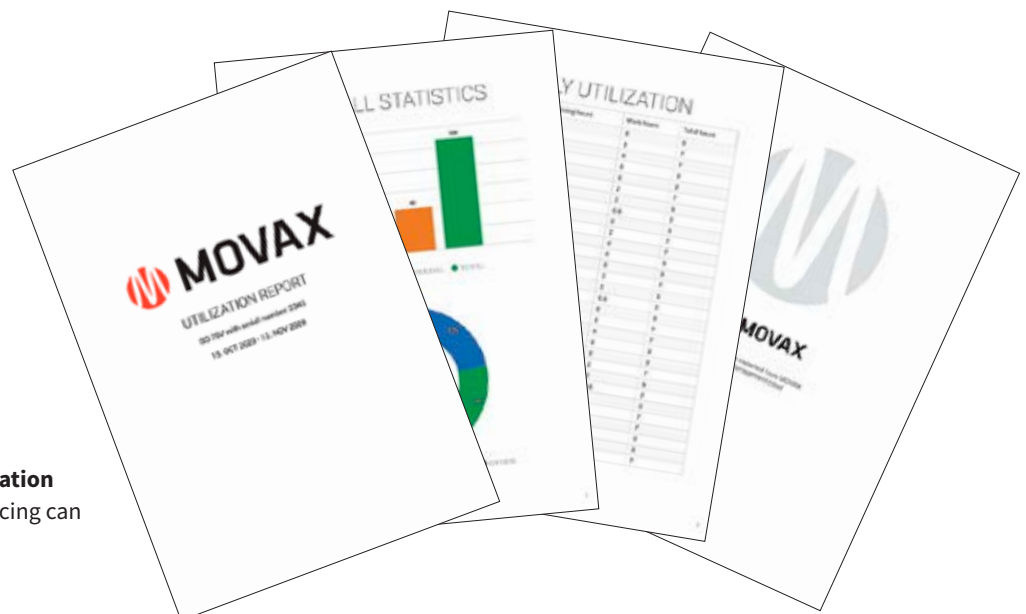

Based on for instance the **'Utilization hours'** a pdf-document for invoicing can be generated.



Tools for analysis

With the mFleetManagement it is possible to prevent failures, predict maintenance requirements and analyse and solve any unexpected problems. mFleetManagement includes versatile tools which enables analysis of the entire work cycle and makes it possible to find deviations and abnormalities. The amount of data varies based on the MOVAX piling equipment in question.

PARAMETERS
For Excavator - Hitachi ZX350

MOVAX

SELECT ALL PARAMETERS OPEN WIDGET MENU

Parameter	Value	Unit	Timestamp
Oil Cooling Fan Speed (RPM)	1500	RPM	2022-09-25 11:38:24.959
Oil Cooling Fan Speed (RPM)	1500	RPM	2022-09-25 11:38:24.975
Oil Cooling Fan Speed (RPM)	1500	RPM	2022-09-25 11:38:24.991
Oil Cooling Fan Speed (RPM)	1500	RPM	2022-09-25 11:38:25.007
Oil Cooling Fan Speed (RPM)	1500	RPM	2022-09-25 11:38:25.023
Oil Cooling Fan Speed (RPM)	1500	RPM	2022-09-25 11:38:25.039
Oil Cooling Fan Speed (RPM)	1500	RPM	2022-09-25 11:38:25.055
Oil Cooling Fan Speed (RPM)	1500	RPM	2022-09-25 11:38:25.071
Oil Cooling Fan Speed (RPM)	1500	RPM	2022-09-25 11:38:25.087
Oil Cooling Fan Speed (RPM)	1500	RPM	2022-09-25 11:38:25.103
Oil Cooling Fan Speed (RPM)	1500	RPM	2022-09-25 11:38:25.119
Oil Cooling Fan Speed (RPM)	1500	RPM	2022-09-25 11:38:25.135
Oil Cooling Fan Speed (RPM)	1500	RPM	2022-09-25 11:38:25.151
Oil Cooling Fan Speed (RPM)	1500	RPM	2022-09-25 11:38:25.167
Oil Cooling Fan Speed (RPM)	1500	RPM	2022-09-25 11:38:25.183
Oil Cooling Fan Speed (RPM)	1500	RPM	2022-09-25 11:38:25.199
Oil Cooling Fan Speed (RPM)	1500	RPM	2022-09-25 11:38:25.215
Oil Cooling Fan Speed (RPM)	1500	RPM	2022-09-25 11:38:25.231
Oil Cooling Fan Speed (RPM)	1500	RPM	2022-09-25 11:38:25.247
Oil Cooling Fan Speed (RPM)	1500	RPM	2022-09-25 11:38:25.263
Oil Cooling Fan Speed (RPM)	1500	RPM	2022-09-25 11:38:25.279
Oil Cooling Fan Speed (RPM)	1500	RPM	2022-09-25 11:38:25.295
Oil Cooling Fan Speed (RPM)	1500	RPM	2022-09-25 11:38:25.311
Oil Cooling Fan Speed (RPM)	1500	RPM	2022-09-25 11:38:25.327
Oil Cooling Fan Speed (RPM)	1500	RPM	2022-09-25 11:38:25.343
Oil Cooling Fan Speed (RPM)	1500	RPM	2022-09-25 11:38:25.359
Oil Cooling Fan Speed (RPM)	1500	RPM	2022-09-25 11:38:25.375
Oil Cooling Fan Speed (RPM)	1500	RPM	2022-09-25 11:38:25.391
Oil Cooling Fan Speed (RPM)	1500	RPM	2022-09-25 11:38:25.407
Oil Cooling Fan Speed (RPM)	1500	RPM	2022-09-25 11:38:25.423
Oil Cooling Fan Speed (RPM)	1500	RPM	2022-09-25 11:38:25.439
Oil Cooling Fan Speed (RPM)	1500	RPM	2022-09-25 11:38:25.455
Oil Cooling Fan Speed (RPM)	1500	RPM	2022-09-25 11:38:25.471
Oil Cooling Fan Speed (RPM)	1500	RPM	2022-09-25 11:38:25.487
Oil Cooling Fan Speed (RPM)	1500	RPM	2022-09-25 11:38:25.503
Oil Cooling Fan Speed (RPM)	1500	RPM	2022-09-25 11:38:25.519
Oil Cooling Fan Speed (RPM)	1500	RPM	2022-09-25 11:38:25.535
Oil Cooling Fan Speed (RPM)	1500	RPM	2022-09-25 11:38:25.551
Oil Cooling Fan Speed (RPM)	1500	RPM	2022-09-25 11:38:25.567
Oil Cooling Fan Speed (RPM)	1500	RPM	2022-09-25 11:38:25.583
Oil Cooling Fan Speed (RPM)	1500	RPM	2022-09-25 11:38:25.599
Oil Cooling Fan Speed (RPM)	1500	RPM	2022-09-25 11:38:25.615
Oil Cooling Fan Speed (RPM)	1500	RPM	2022-09-25 11:38:25.631
Oil Cooling Fan Speed (RPM)	1500	RPM	2022-09-25 11:38:25.647
Oil Cooling Fan Speed (RPM)	1500	RPM	2022-09-25 11:38:25.663
Oil Cooling Fan Speed (RPM)	1500	RPM	2022-09-25 11:38:25.679
Oil Cooling Fan Speed (RPM)	1500	RPM	2022-09-25 11:38:25.695
Oil Cooling Fan Speed (RPM)	1500	RPM	2022-09-25 11:38:25.711
Oil Cooling Fan Speed (RPM)	1500	RPM	2022-09-25 11:38:25.727
Oil Cooling Fan Speed (RPM)	1500	RPM	2022-09-25 11:38:25.743
Oil Cooling Fan Speed (RPM)	1500	RPM	2022-09-25 11:38:25.759
Oil Cooling Fan Speed (RPM)	1500	RPM	2022-09-25 11:38:25.775
Oil Cooling Fan Speed (RPM)	1500	RPM	2022-09-25 11:38:25.791
Oil Cooling Fan Speed (RPM)	1500	RPM	2022-09-25 11:38:25.807
Oil Cooling Fan Speed (RPM)	1500	RPM	2022-09-25 11:38:25.823
Oil Cooling Fan Speed (RPM)	1500	RPM	2022-09-25 11:38:25.839
Oil Cooling Fan Speed (RPM)	1500	RPM	2022-09-25 11:38:25.855
Oil Cooling Fan Speed (RPM)	1500	RPM	2022-09-25 11:38:25.871
Oil Cooling Fan Speed (RPM)	1500	RPM	2022-09-25 11:38:25.887
Oil Cooling Fan Speed (RPM)	1500	RPM	2022-09-25 11:38:25.903
Oil Cooling Fan Speed (RPM)	1500	RPM	2022-09-25 11:38:25.919
Oil Cooling Fan Speed (RPM)	1500	RPM	2022-09-25 11:38:25.935
Oil Cooling Fan Speed (RPM)	1500	RPM	2022-09-25 11:38:25.951
Oil Cooling Fan Speed (RPM)	1500	RPM	2022-09-25 11:38:25.967
Oil Cooling Fan Speed (RPM)	1500	RPM	2022-09-25 11:38:25.983
Oil Cooling Fan Speed (RPM)	1500	RPM	2022-09-25 11:38:25.999

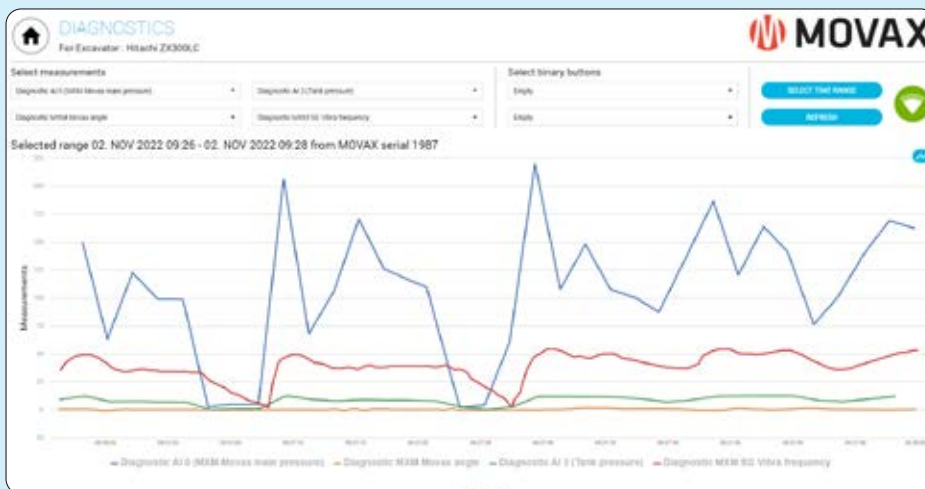

mLOGBOOK

FEATURES

mLogbook is a documentation and reporting tool which provides essential data related to the piling process and the piling or foundation project.

The piling information is collected by the MOVAX Control System and stored in the MOVAX Control System's excavator module. To report the piling works the operator only has to input the pile number, the system will take care of the rest. Data concerning site and pile information is added by the user (engineer or equal) and the system will generate automatically illustrative, ready-made reports - including both measured and calculated data - which provide essential information about the piling process and its quality.

mLogbook is compatible with commonly used global positioning systems such as Trimble, Novatron and Leica which adds also the positioning data to the pile reports. Optionally independent global positioning sensors (RTK GNSS) can also be provided to allow for the addition of the exact pile positioning data without a third party global positioning system.

Project overview

Specific reports are generated for MOVAX piling equipment including MOVAX side grip pile drivers, MOVAX piling hammers, MOVAX piling drills and MOVAX multi-tool piling leaders including the associated tooling,

The 'Project overview' provides the information of all main projects and also sub-projects.

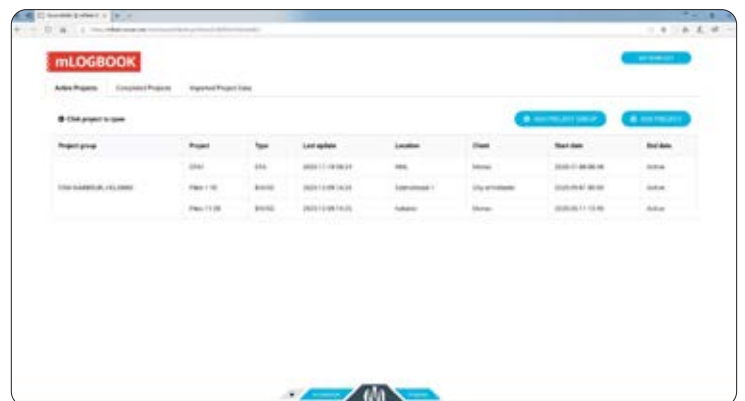

SG project report

The mLogbook 'project report' includes all the information related to the piling or foundation project including pile type & dimensions, the depth to which the pile has been driven with the various tools and for instance in the case of load bearing piles also information related to the pile set.

Different parameters are reported for the different MOVAX piling equipment.

mLOGBOOK

PROJECT REPORT SG

Main project	Bridge construction	MOVAX piling equipment	SG-60, sn1462	Operator	Tom Jackson
Sub project	SE Exit			Start date	2020-05-12
Location	Islington, London	Pile type	Sheet piles	End date	2020-05-31
Customer	Road constructors ltd	Note!			
Contract number	923000-A1				

Pile#	Position data	Pile type	Pile dimensions [mm]	Pile length [m]	Total depth [m]	Depth [m]	Angle (avg) [°]	Date
1	53°26'54.036"N 2°12'47.012"W	AZ 13-770	770	12	7.877	6.143	0,0	2020-05-13 13:25
2	53°26'54.037"N 2°12'47.012"W	AZ 13-770	770	12	9.274	8.189	-0,1	2020-05-13 13:58
3	53°26'54.038"N 2°12'47.012"W	AZ 13-770	770	12	11.926	10.121	0,4	2020-05-13 14:38
4	53°26'54.039"N 2°12'47.012"W	AZ 13-770	770	12	7.062	6.157	0,2	2020-05-13 14:58
5	53°26'54.040"N 2°12'47.012"W	AZ 13-770	770	12	6.907	4.763	0,0	2020-05-13 15:05
6	53°26'54.041"N 2°12'47.012"W	AZ 13-770	770	12	6.368	5.921	0,0	2020-05-13 15:19
7	53°26'54.038"N 2°12'47.012"W	AZ 13-770	770	12	11.926	10.121	-0,3	2020-05-13 14:38
8	53°26'54.041"N 2°12'47.012"W	AZ 13-770	770	12	6.368	5.921	0,0	2020-05-13 15:19
9	53°26'54.038"N 2°12'47.012"W	AZ 13-770	770	12	11.926	10.121	0,1	2020-05-13 14:38
10	53°26'54.041"N 2°12'47.012"W	AZ 13-770	770	12	6.368	5.921	-0,1	2020-05-13 15:19
11	53°26'54.038"N 2°12'47.012"W	AZ 13-770	770	12	11.926	10.121	0,2	2020-05-13 14:38
12	53°26'54.041"N 2°12'47.012"W	AZ 13-770	770	12	6.368	5.921	0,0	2020-05-13 15:19
13	53°26'54.038"N 2°12'47.012"W	AZ 13-770	770	12	11.926	10.121	0,1	2020-05-13 14:38
14	53°26'54.041"N 2°12'47.012"W	AZ 13-770	770	12	6.368	5.921	-0,1	2020-05-13 15:19
15	53°26'54.038"N 2°12'47.012"W	AZ 13-770	770	12	11.926	10.121	0,2	2020-05-13 14:38
16	53°26'54.041"N 2°12'47.012"W	AZ 13-770	770	12	6.368	5.921	0,2	2020-05-13 15:19
17	53°26'54.038"N 2°12'47.012"W	AZ 13-770	770	12	11.926	10.121	0,3	2020-05-13 14:38
18	53°26'54.041"N 2°12'47.012"W	AZ 13-770	770	12	6.368	5.921	0,1	2020-05-13 15:19
19	53°26'54.038"N 2°12'47.012"W	AZ 13-770	770	12	11.926	10.121	0,1	2020-05-13 14:38
20	53°26'54.041"N 2°12'47.012"W	AZ 13-770	770	12	6.368	5.921	0,3	2020-05-13 15:19
21	53°26'54.038"N	AZ 13-770	770	12	11.926	10.121	0,0	2020-05-13 14:38

MOVAX SG side grip pile driver -report:

Penetration rate, Centrifugal force, Working pressure, Eccentric moment, RPM, Inclination

DH project report

The mLogbook 'project report' includes all the information related to the piling or foundation project including pile type & dimensions, the depth to which the pile has been driven with the various tools and for instance in the case of load bearing piles also information related to the pile set.

Different parameters are reported for the different MOVAX piling equipment.

mLOGBOOK

PROJECT REPORT DH

Main project	Bridge construction	MOVAX piling equipment	DH-25, sn1574	Operator	Tom Jackson
Sub project	SE Exit			Start date	2020-05-12
Location	Islington, London	Pile type	Sheet piles	End date	2020-05-31
Customer	Road constructors ltd	Note!			
Contract number	923000-A1				

Pile#	Position data	Pile type	Pile dimensions [mm]	Pile length [m]	Total depth [m]	Depth DH [m]	Blows DH [no]	Angle (avg) [°]	Pile set criterion			Date
									Energy [kNm]	Blows	Set [mm]	
1	53°26'54.036"N 2°12'47.012"W	AZ 13-770	770	12	7.877	1.734	56	0,0	21,9/20	10/10	19,1/20	2020-05-13 13:25
2	53°26'54.037"N 2°12'47.012"W	AZ 13-770	770	12	9.274	1.085	90	-0,1	20,8/20	10/10	13,6/20	2020-05-13 13:58
3	53°26'54.038"N 2°12'47.012"W	AZ 13-770	770	12	11.926	1.805	125	0,4	20,0/20	10/10	20,2/20	2020-05-13 14:38
4	53°26'54.039"N 2°12'47.012"W	AZ 13-770	770	12	7.062	0.905	64	0,2	21,3/20	10/10	14,8/20	2020-05-13 14:58
5	53°26'54.040"N 2°12'47.012"W	AZ 13-770	770	12	6.907	2.144	86	0,0	21,5/20	8/10	17,7/20	2020-05-13 15:05
6	53°26'54.041"N 2°12'47.012"W	AZ 13-770	770	12	6.368	0.447	13	0,0	20,1/20	10/10	17,6/20	2020-05-13 15:19
7	53°26'54.038"N 2°12'47.012"W	AZ 13-770	770	12	11.926	1.805	125	-0,3	22,0/20	10/10	18,9/20	2020-05-13 14:38
8	53°26'54.041"N 2°12'47.012"W	AZ 13-770	770	12	6.368	0.447	13	0,0	22,2/20	9/10	16,3/20	2020-05-13 15:19
9	53°26'54.038"N 2°12'47.012"W	AZ 13-770	770	12	11.926	1.805	125	0,1	21,1/20	10/10	14,6/20	2020-05-13 14:38
10	53°26'54.041"N 2°12'47.012"W	AZ 13-770	770	12	6.368	0.447	13	-0,1	22,3/20	10/10	18,6/20	2020-05-13 15:19
11	53°26'54.038"N 2°12'47.012"W	AZ 13-770	770	12	11.926	1.805	125	0,2	22,2/20	10/10	17,1/20	2020-05-13 14:38
12	53°26'54.041"N 2°12'47.012"W	AZ 13-770	770	12	6.368	0.447	13	0,0	21,8/20	10/10	17,7/20	2020-05-13 15:19
13	53°26'54.038"N 2°12'47.012"W	AZ 13-770	770	12	11.926	1.805	125	0,1	21,2/20	10/10	15,3/20	2020-05-13 14:38
14	53°26'54.041"N 2°12'47.012"W	AZ 13-770	770	12	6.368	0.447	13	-0,1	20,1/20	6/10	17,4/20	2020-05-13 15:19
15	53°26'54.038"N 2°12'47.012"W	AZ 13-770	770	12	11.926	1.805	125	0,2	21,1/20	10/10	14,6/20	2020-05-13 14:38
16	53°26'54.041"N 2°12'47.012"W	AZ 13-770	770	12	6.368	0.447	13	0,2	22,0/20	10/10	15,4/20	2020-05-13 15:19
17	53°26'54.038"N 2°12'47.012"W	AZ 13-770	770	12	11.926	1.805	125	0,3	21,9/20	10/10	21,0/20	2020-05-13 14:38
18	53°26'54.041"N 2°12'47.012"W	AZ 13-770	770	12	6.368	0.447	13	0,1	19,7/20	10/10	13,1/20	2020-05-13 15:19
19	53°26'54.038"N 2°12'47.012"W	AZ 13-770	770	12	11.926	1.805	125	0,1	21,6/20	10/10	13,2/20	2020-05-13 14:38
20	53°26'54.041"N 2°12'47.012"W	AZ 13-770	770	12	6.368	0.447	13	0,3	21,7/20	10/10	20,1/20	2020-05-13 15:19
21	53°26'54.038"N 2°12'47.012"W	AZ 13-770	770	12	11.926	1.805	125	0,0	22,4/20	5/10	14,8/20	2020-05-13 14:38

MOVAX DH side grip pile driver -report:
Penetration rate, Rate per blow, Drop height, Energy, Inclination

CFA project report

The mLogbook 'project report' includes all the information related to the piling or foundation project including pile type & dimensions, the depth to which the pile has been driven with the various tools and for instance in the case of load bearing piles also information related to the pile set.

Different parameters are reported for the different MOVAX piling equipment.

mLOGBOOK

PROJECT REPORT

Main project	Bridge construction	MOVAX piling equipment	MPL-400/CFA, sn 1255	Operator	Tom Jackson
Sub project	SE Exit			Start date	2020-05-12
Location	Islington, London	Pile type	CFA	End date	2020-05-31
Customer	Road constructors ltd	Note!			
Contract number	923000-A1				

Pile#	Position data	Pile type	Pile dimensions [mm]	Pile depth [m]	Angle [°]	Torque (average) [kNm]	Concrete volume [m³]	Concrete pressure (average) [bar]	Start time	End time	Elapsed time	Date
1	53°26'54.036"N 2°12'47.012"W	CFA	400	10	0,1	41,1	5,39	68	12:04:40	12:45:34	0:40:54	2020-05-12
2	53°26'54.037"N 2°12'47.012"W	CFA	400	10	-0,3	36,2	5,55	37	8:42:24	8:55:55	0:13:31	2020-05-13
3	53°26'54.038"N 2°12'47.012"W	CFA	400	10	-0,4	36,4	5,33	21	9:44:22	9:59:20	0:14:58	2020-05-13
4	53°26'54.039"N 2°12'47.012"W	CFA	400	10	0,1	35,5	5,72	48	10:55:33	11:34:22	0:38:49	2020-05-13
5	53°26'54.040"N 2°12'47.012"W	CFA	400	10	-0,1	38,9	5,11	24	12:04:40	12:45:34	0:40:54	2020-05-13
6	53°26'54.041"N 2°12'47.012"W	CFA	400	10	0,2	39,7	5,64	28	13:07:22	13:30:22	0:23:00	2020-05-13
7	53°26'54.038"N 2°12'47.012"W	CFA	400	10	0,4	36,8	5,21	79	13:45:55	13:59:22	0:13:27	2020-05-13
8	53°26'54.041"N 2°12'47.012"W	CFA	400	10	-0,2	36,3	5,03	27	14:15:00	14:26:22	0:11:22	2020-05-13
9	53°26'54.038"N 2°12'47.012"W	CFA	400	10	0,0	39,9	5,20	73	14:47:44	15:13:20	0:25:36	2020-05-13
10	53°26'54.041"N 2°12'47.012"W	CFA	400	10	0,0	37,6	5,79	64	14:15:00	14:26:22	0:11:22	2020-05-14
11	53°26'54.038"N 2°12'47.012"W	CFA	400	10	-0,3	36,5	5,87	33	13:07:22	13:30:22	0:23:00	2020-05-15
12	53°26'54.041"N 2°12'47.012"W	CFA	400	10	0,1	37,4	5,73	60	12:04:40	12:45:34	0:40:54	2020-05-16
13	53°26'54.038"N 2°12'47.012"W	CFA	400	10	-0,3	39,3	5,24	59	8:42:24	8:55:55	0:13:31	2020-05-17
14	53°26'54.041"N 2°12'47.012"W	CFA	400	10	-0,1	41,0	5,91	76	9:44:22	9:59:20	0:14:58	2020-05-18
15	53°26'54.038"N 2°12'47.012"W	CFA	400	10	-0,3	41,6	5,44	58	10:55:33	11:34:22	0:38:49	2020-05-18
16	53°26'54.041"N 2°12'47.012"W	CFA	400	10	-0,1	40,1	5,44	78	12:04:40	12:45:34	0:40:54	2020-05-25
17	53°26'54.038"N 2°12'47.012"W	CFA	400	10	-0,1	38,2	5,67	75	8:42:24	8:55:55	0:13:31	2020-05-26
18	53°26'54.041"N 2°12'47.012"W	CFA	400	10	0,1	37,4	5,41	30	9:44:22	9:59:20	0:14:58	2020-05-26
19	53°26'54.038"N 2°12'47.012"W	CFA	400	10	-0,1	37,6	5,07	35	10:55:33	11:34:22	0:38:49	2020-05-26

MOVAX Multi-tool piling leader CFA -report:

Position data, Pile type, Pile dimensions, Pile depth, Angle, Torque, Concrete volume, Concrete pressure, Start time, End time, Elapsed time, Date

MSL project report

The mLogbook 'project report' includes all the information related to the piling or foundation project including pile type & dimensions, the depth to which the pile has been driven with the various tools and for instance in the case of load bearing piles also information related to the pile set.

Different parameters are reported for the different MOVAX piling equipment.

mLOGBOOK

PROJECT REPORT Column stabilisation

Main project	Bridge construction	Stabilization method	column stabilization	Operator	Tom Jackson
Sub project	SE Exit	Binder material	Cement	Start date	2020-05-12
Location	Islington, London	Jobsite data (measured)		End date	2020-05-31
Customer	Road constructors ltd	Total mass	2328 kg	Note!	
Contract number	923000-A1	Total volume	32 m ³		

Column #	Column ID	Position data	PF ID	Section dimensions [mm]	Total depth [m]	Binder [kg/m ³]	Total amount [kg]	Total volume [m ³]	Pressure [bar]	Flow [kg/s]	Feeding time [hh:min:ss]	Mixing time [hh:min:ss]	Date
1	1,1	53°26'54.036"N 2°12'47.012"W	K7R234	800	15	88	530	5,39	0,2	2,9	0:07:45	0:08:34	2020-05-12
2	1,2	53°26'54.037"N 2°12'47.012"W	K7R234	800	15	89	510	5,55	0,3	2,7	0:06:45	0:07:34	2020-05-13
3	1,3	53°26'54.038"N 2°12'47.012"W	K7R234	800	15	87	540	5,33	0,2	3,1	0:08:34	0:07:45	2020-05-13
4	1,4	53°26'54.039"N 2°12'47.012"W	K7R234	800	15	85	525	5,72	0,4	3,2	0:07:34	0:06:45	2020-05-13
5	1,5	53°26'54.040"N 2°12'47.012"W	K7R234	800	15	86	530	5,11	0,2	3,1	0:07:45	0:08:34	2020-05-13
6	1,6	53°26'54.041"N 2°12'47.012"W	K7R234	800	15	83	525	5,64	0,2	3,3	0:06:45	0:08:34	2020-05-13
7	1,7	53°26'54.038"N 2°12'47.012"W	K7R234	800	15	84	530	5,21	0,2	2,6	0:08:34	0:07:34	2020-05-13
8	2,1	53°26'54.041"N 2°12'47.012"W	K7R234	800	15	89	510	5,03	0,3	2,9	0:07:34	0:07:45	2020-05-13
9	2,2	53°26'54.038"N 2°12'47.012"W	K7R234	800	15	88	540	5,20	0,2	2,9	0:07:45	0:06:45	2020-05-13
10	2,3	53°26'54.041"N 2°12'47.012"W	K7R234	800	15	89	525	5,79	0,4	2,7	0:06:45	0:08:34	2020-05-14
11	2,4	53°26'54.038"N 2°12'47.012"W	K7R234	800	15	87	530	5,87	0,2	3,1	0:08:34	0:08:34	2020-05-15
12	2,5	53°26'54.041"N 2°12'47.012"W	K7R234	800	15	85	525	5,73	0,2	3,2	0:07:34	0:07:34	2020-05-16
13	2,6	53°26'54.038"N 2°12'47.012"W	K7R234	800	15	86	530	5,24	0,2	3,1	0:07:45	0:07:45	2020-05-17
14	2,7	53°26'54.041"N 2°12'47.012"W	K7R234	800	15	83	510	5,91	0,3	3,3	0:06:45	0:06:45	2020-05-18
15	3,1	53°26'54.038"N 2°12'47.012"W	K7R234	800	15	84	540	5,44	0,2	2,6	0:08:34	0:08:34	2020-05-18
16	3,2	53°26'54.041"N 2°12'47.012"W	K7R234	800	15	89	525	5,44	0,4	2,9	0:07:34	0:08:34	2020-05-25
17	3,3	53°26'54.038"N 2°12'47.012"W	K7R234	800	15	88	530	5,67	0,2	2,9	0:07:45	0:07:34	2020-05-26
18	3,4	53°26'54.041"N 2°12'47.012"W	K7R234	800	15	89	525	5,41	0,2	2,7	0:06:45	0:07:45	2020-05-26
19	3,5	53°26'54.038"N 2°12'47.012"W	K7R234	800	15	88	530	5,07	0,2	3,1	0:08:34	0:06:45	2020-05-26
20	3,6	53°26'54.041"N 2°12'47.012"W	K7R234	800	15	89	510	5,86	0,3	3,2	0:07:34	0:08:34	2020-05-26

MOVAX Column stabilisation leader MSL -report:

Position data, Pile type, Pile dimensions, Pile depth, Angle, Torque, Binder amount, Feed pressure
Ascent rate, Start time, End time, Elapsed time, Date

SG pile report

Based on the project report it is possible to generate pile specific reports for each individual pile; and for each individual MOVAX piling equipment.

mLOGBOOK

PILE REPORT SG

Pile# 12

Main project	Bridge construction	Operator	Tom Jackson	MOVAX piling equipment	SG-60, sn 7354
Sub project	SE Exit	Date	2020-05-12	Piling technology	Vibratory pile driver
Location	Islington, London	Start time	10:19:00	Vibration time	09:45
Customer	Road constructors ltd	End time	10:30:10	Pile type & dimensions	AZ 13-770 / 770 mm
Contract number	923000-A1	Elapsed time	10:10	Total depth	7.0 m
Note!					

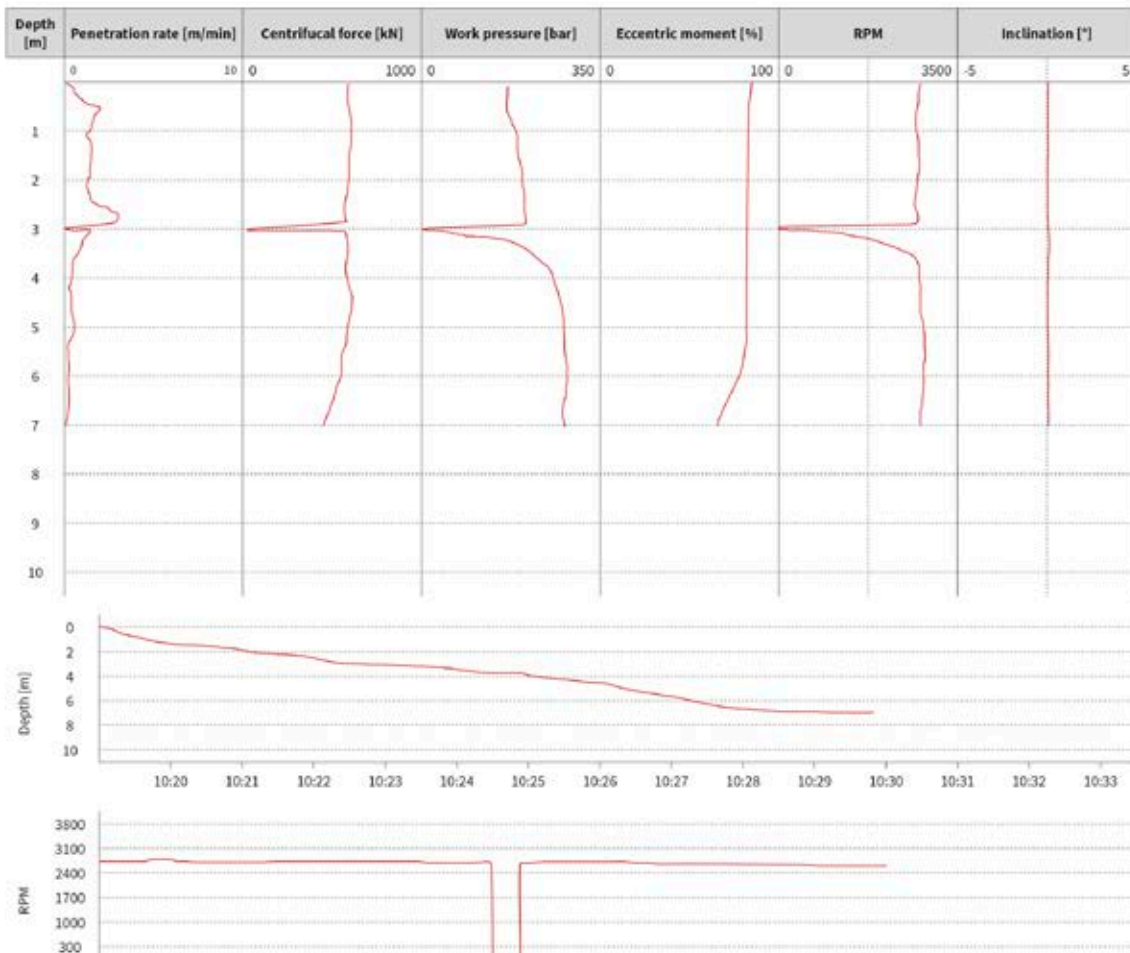

MOVAX SG side grip pile driver -report:

Penetration rate, Centrifugal force, Working pressure, Eccentric moment, RPM, Inclination

DH pile report

Based on the project report it is possible to generate pile specific reports for each individual pile; and for each individual MOVAX piling equipment.

mLOGBOOK

PILE REPORT DH

Pile# 12

Main project	Bridge construction	Operator	Tom Jackson	MOVAX piling equipment	DH-25, sn 8743
Sub project	SE Exit	Date	2020-05-12		
Location	Islington, London	Start time	10:49:05	Piling technology	Hydraulic hammer
Customer	Road constructors ltd	End time	10:56:10	Blow count	240
Contract number	923000-A1	Elapsed time	07:05	Pile type & dimensions	AZ 13-770 / 770 mm
Note!				Pile type	8.1 m
				Pile set criterion	20 kJ, 10 blows, 20 mm

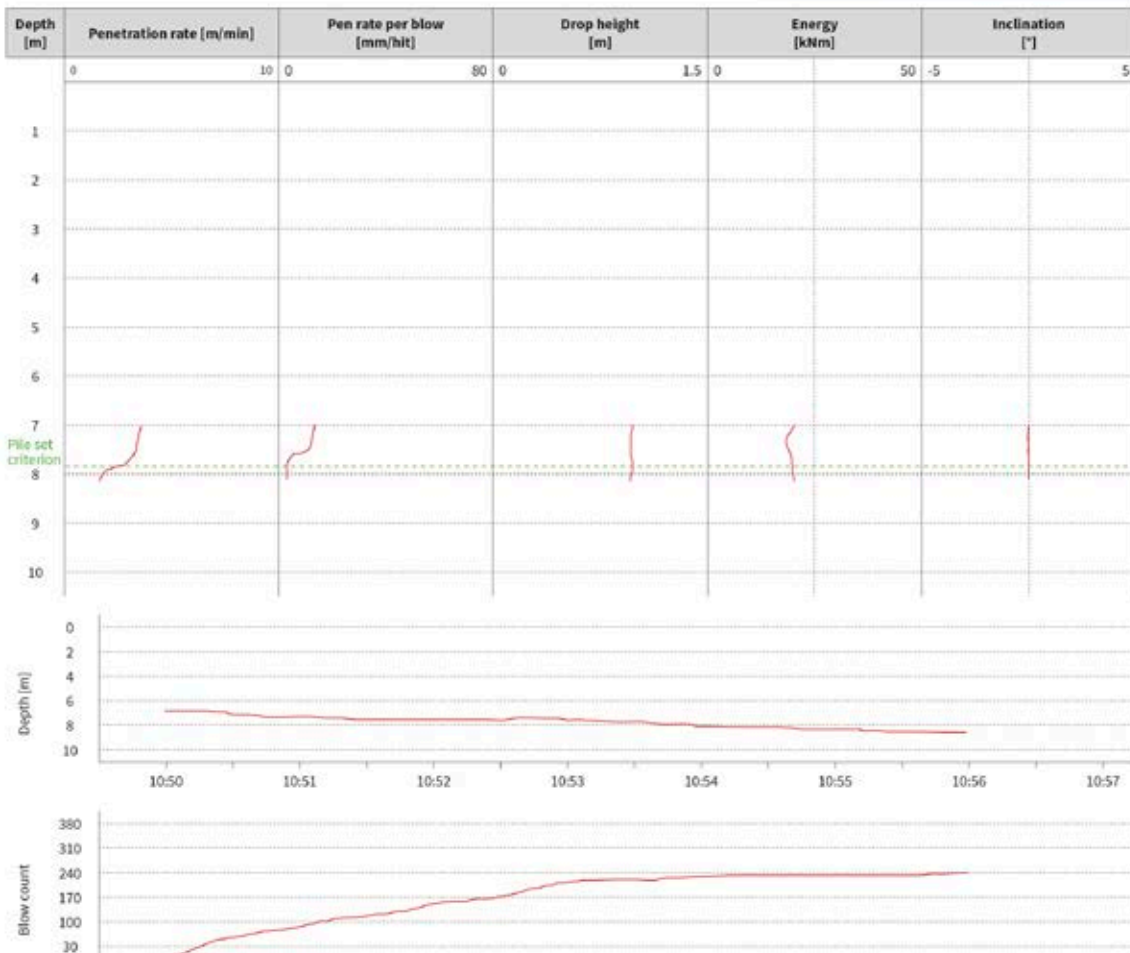

MOVAX DH side grip pile driver -report:
Penetration rate, Rate per blow, Drop height, Energy, Inclination

CFA pile report

Based on the project report it is possible to generate pile specific reports for each individual pile; and for each individual MOVAX piling equipment.

mLOGBOOK

PILE REPORT CFA

Pile# 12

Main project	Bridge construction	Operator	Tom Jackson	MOVAX piling equipment	MPL-400/CFA, sn 1255
Sub project	SE Exit	Date	2020-05-12	Pile type	CFA
Location	Islington, London	Start time	12:50:00	Auger rev's	384
Customer	Road constructors ltd	End time	12:53:10	Pile dimensions/depth	dia 400 mm / 10 m
Contract number	923000-A1	Elapsed time	03:10	Concrete volume	6 m ³
Note!				Oversupply	25%

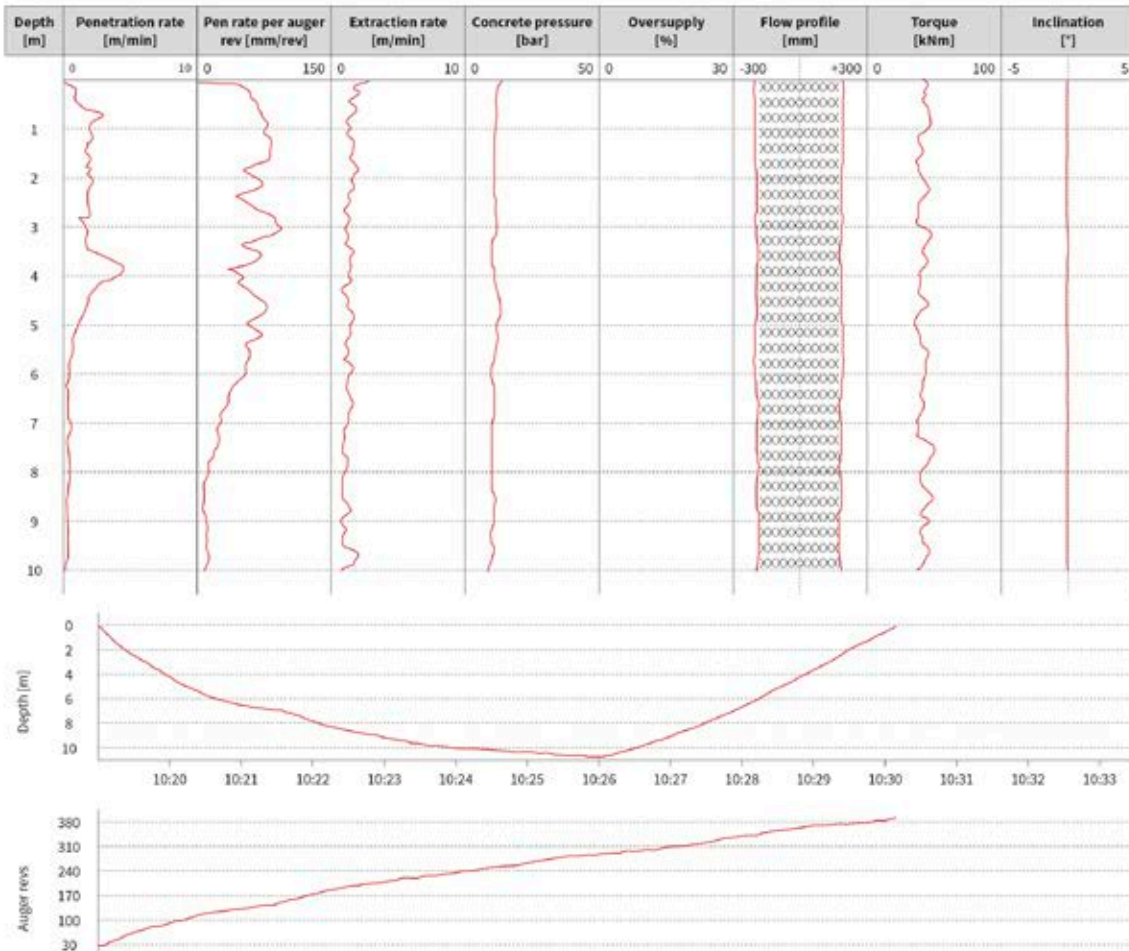

MOVAX Multi-tool piling leader CFA -report:

Position data, Pile type, Pile dimensions, Pile depth, Angle, Torque, Concrete volume, Concrete pressure, Start time, End time, Elapsed time, Date

MSL column report

Based on the project report it is possible to generate pile specific reports for each individual pile; and for each individual MOVAX piling equipment.



COLUMN REPORT Column stabilisation

COLUMN ID 3,4

Main project	Bridge construction	Operator	Tom Jackson	Stabilization method	column
Sub project	SE Exit	Date	2020-05-12	Total depth	15 m
Location	Islington, London	Start time	12:50:00	Total mass [kg]	525
Customer	Road constructors ltd	End time	12:53:10	Column dimension	600 mm
Contract number	923000-A1	Elapsed time	03:10	Total volume	5,34 m³

Note!

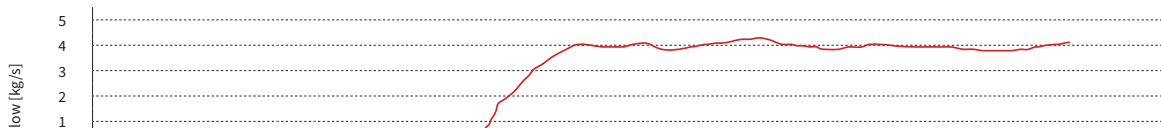
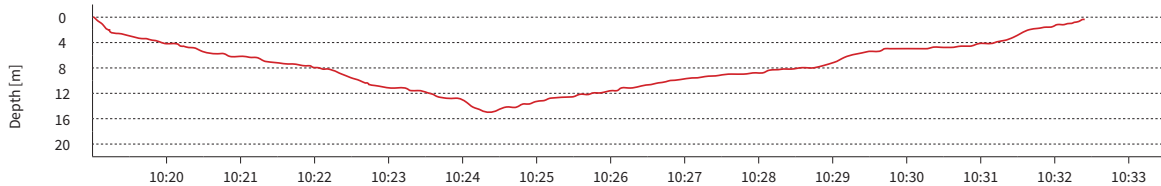
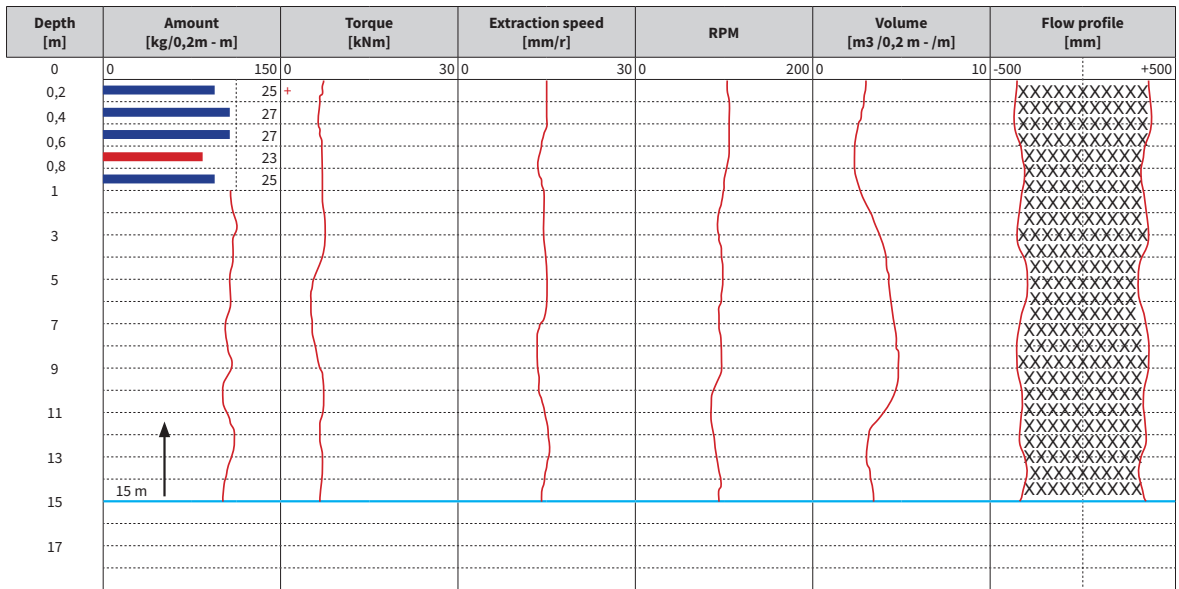

MOVAX Column stabilisation leader MSL -report:

Position data, Pile type, Pile dimensions, Pile depth, Angle, Torque, Binder amount, Feed pressure, Ascent rate, Start time, End time, Elapsed time, Date

INTRODUCTION

ADAPTERS

Pin-connectors

Pin connectors consist of a welded adapter bracket with removable pins (Note! Pins are not included in Movax Oy's delivery, unless separately agreed upon). When connecting the MOVAX piling equipment to the excavator all mechanical, hydraulic and electrical connections are made manually.

Pin-connectors are based on the excavator brand and model. MOVAX Adapters are manufactured to match the specific dimensions of the excavator's bucket connection.



(Mechanical) quick couplers

Quick couplers allow for a faster change of the MOVAX piling equipment or other tooling than for instance traditional pin connectors. When connecting the MOVAX piling equipment to the excavator, the mechanical connection is made by connecting the MOVAX adapter with the excavator's quick coupler. The hydraulic and electrical connections are made manually. MOVAX Adapters are custom-made in accordance with the dimensions of the excavator's quick coupler.



Typical mechanical quick couplers are, for example:

- **S-series** – S60, S70 etc. Note! MOVAX piling equipment and excavator specific MOVAX Adapters are customised according to the S-series standard.
- **Pin Grabber** – Miller etc.
- **CW-series** – Verachter etc.
- **SW-series** – Liebherr etc.

Automatic quick couplers

Automatic quick couplers allow for an even faster change of MOVAX piling equipment and other tooling. When connecting the MOVAX piling equipment to the excavator all connections including the mechanical, hydraulic and electrical connections are made automatically.

MOVAX Adapters are manufactured according the quick coupler brand and model and its specific dimensions.

Typical automatic quick couplers are, for example:

- **OilQuick** – OQ60, OQ70, OQ80 etc.
- **Likufix** – SW33, SW48 etc.



Other couplers & connectors

MOVAX Adapters for other type of couplers are manufactured according to the excavator's coupler or connector and its specific dimensions.

Typical couplers/connectors are, for example:

- **NTP**
- **Atlas**
- **Lehnhoff**
- **Liebherr 900**
- **Gjerstad**





STATE-OF-THE ART MANUFACTURING

QUALITY

MOVAX is made in Hämeenlinna, Finland utilising high-class materials, equipment and components – and modern, state-of-the-art production technologies and machinery ensuring the highest possible quality of manufacture.

Movax Oy's own production is supported by a proven, high quality network of partners. The state-of-the-art production facilities & machinery, long-term, established and reliable partners combined with optimized logistics ensure both quality and cost-efficiency – as well as fast, on-time deliveries.



CERTIFIED MANAGEMENT SYSTEM

Movax Oy's Quality Management System is certified in accordance with ISO 9001-2015.





1137



PSALONEN OY

SERVICES

MOVAX mFleetCare

MOVAX mFleetCare™ is a total service solution intended to maximise the productivity and the quality of the piling work when using MOVAX piling equipment. The goal of MOVAX mFleetCare is to ensure the maximum availability of the MOVAX piling equipment and to provide the operator with the required skills and best practices - and with superior support in all conditions and at all times – thus enabling the operator to perform the work with the highest productivity, accuracy and quality.

MOVAX mFleetCare addresses all aspects of ensuring the highest possible availability and the best use of MOVAX piling equipment. mFleetCare covers audits and inspections, preventive and corrective maintenance, training services for the continued growth of expertise and skills, efficient and fast on-site and remote support, installation and calibration services, as well as engineering and spare parts services.

MOVAX mFleetCare services are provided world wide by Movax Oy's own specialists and by a trained and certified network of partners. In addition, Movax Oy utilises the most modern IT-based solutions to provide support anywhere in the world, always and at any time.



MOVAX mFleetCare



Audits



Preventive maintenance



Corrective maintenance



Training services



Installation services



Engineering services



Spare parts



SERVICES

GLOBALLY LOCAL

MOVAX supports its world wide customers centrally from the factory and engineering office located in Hämeenlinna, Finland AND through a network of local partners all over the world.

MOVAX local partners are both trained and certified, and thus highly skilled, in providing the necessary support and after sales services to local customers in order to ensure the highest possible availability and reliability of the MOVAX piling equipment at all times and under all circumstances.

MOVAX also cooperates continuously with end-users as well as with its local partners to continuously develop the MOVAX piling technology. The global coverage and expertise ensures that varying conditions and requirements are truly taken into consideration in an optimised manner.



WORLD-WIDE LOCAL SUPPORT IN MORE THAN 35 COUNTRIES

for MOVAX world wide partners kindly refer to:

www.movax.com -> Contact us

MOVAX WAY-OF-PILING

UNIQUE, INNOVATIVE & VALUE-ADDING SOLUTIONS

MOVAX way-of-piling™ provides a most efficient, fast, flexible and versatile, accurate, safe and reliable way-of-working which results in a higher productivity and thus significant overall time and cost savings in a wide range of piling and foundation – soil improvement - applications.

BENEFITS

- **A total piling & foundation solution**
A complete range of piling equipment and customised solutions for driven, bored and drilled piles
- **Unique, value-adding technology**
Fast. Efficient. Versatile. Accurate. Safe. Reliable.
- **Globally proven technology & solutions**
 - Since 1993
 - Over 3000 deliveries
 - All over the world
 - Site & soil conditions from the arctic to the tropic
 - Numerous applications from rail, road and civil to waterways & piers, environmental & utilities
- **Globally supported sales and service**



HIGHER PRODUCTIVITY – SIGNIFICANT SAVINGS

Efficient. Fast. Versatile. Accurate. Safe. Reliable.



CIVIL



ROAD



RAIL



UTILITIES



ENERGY &
ENVIRONMENT



WATERWAYS



HIGHER PRODUCTIVITY - SIGNIFICANT SAVINGS
fast. efficient. versatile. accurate. safe. reliable.

Movax Oy

Tölkkimäentie 10
FI-13130 Hämeenlinna, Finland

Tel. +358 3 628 070
marketing@movax.fi | movax.com

*Please refer to www.movax.com
for worldwide, certified partners.*

